

18 Diagrams

18.1	Hydraulic schematics	18-3
18.1.1	Implement hydraulic schematic	18-3
18.1.2	Implement valve configuration schematic (drawbar)	18-5
18.1.3	Implement valve configuration schematic (3-point linkage)	18-7
18.1.4	Drive train hydraulic schematic	18-9
18.2	Electrical schematics	18-13
18.2.1	MT900E cab schematic	18-15
18.2.2	MT900E chassis schematic	18-16
18.2.3	Throttle lever position sensor	18-17
18.2.4	Rear PTO switch	18-18
18.2.5	Raise work switch	18-19
18.2.6	Topcon X-30	18-20
18.2.7	Armrest 1	18-21
18.2.8	Roof controller	18-22
18.2.9	Park brake	18-23
18.2.10	Engine control module 1	18-24
18.2.11	AGCO EDT service connector	18-25
18.2.12	Dash cluster	18-26
18.2.13	Implement solenoids	18-27
18.2.14	Front and rear lighting	18-28
18.2.15	Fuse block 2	18-29
18.2.16	ISO service connector	18-30
18.2.17	ISO implement connector	18-31
18.2.18	Guidance	18-32
18.2.19	Front lighting ECU	18-33
18.2.20	Rear lighting ECU	18-34
18.2.21	Roof front and rear turn lamps	18-35
18.2.22	Cab	18-36
18.2.23	Exhaust and NOX sensor	18-37
18.2.24	Engine Control Module 2	18-38
18.2.25	Engine control module	18-39
18.2.26	Engine AB switch	18-40
18.2.27	Fan control	18-41
18.2.28	Fuel line sensor	18-42
18.2.29	Standard conditioner group	18-43
18.2.30	HVAC high pressure switch	18-44
18.2.31	HVAC deluxe module	18-45
18.2.32	Cab unswitched power	18-46
18.2.33	Belt line flood lights	18-47
18.2.34	Hood lighting	18-48
18.2.35	Flood and hazard switch	18-49
18.2.36	Hood harness and courtesy lamp	18-50
18.2.37	Porch and flood lights	18-51
18.2.38	Rear working lights	18-52
18.2.39	Heated mirrors	18-53
18.2.40	Mirror switch	18-54
18.2.41	USB charging port	18-55
18.2.42	Power strip	18-56
18.2.43	Radar	18-57
18.2.44	Radio and speakers	18-58
18.2.45	Woofers	18-59

18.2.46	Remote steer	18-60
18.2.47	Rear reverse lamps	18-61
18.2.48	Seat group	18-62
18.2.49	Top and bottom starter	18-63
18.2.50	ECM power	18-64
18.2.51	Cab / Chassis pass through	18-65
18.2.52	Key start switch	18-66
18.2.53	Armrest 2	18-67
18.2.54	Rear hitch	18-68
18.2.55	Transmission filter bypass switch	18-69
18.2.56	Steering sensor box	18-70
18.2.57	Rear lighting	18-71
18.2.58	Trailer lights	18-72
18.2.59	Trailer auxiliary A switch	18-73
18.2.60	Trans solenoids	18-74
18.2.61	Transmission sensors	18-75
18.2.62	Hydraulic oil switch	18-76
18.2.63	Decel pedal sensor	18-77
18.2.64	Articulation sensor	18-78
18.2.65	Front and rear washer	18-79
18.2.66	Roof	18-80
18.3	Connector location diagrams	18-81
18.3.1	Battery group connector location diagram	18-83
18.3.2	Cab electrical bottom connector location diagram	18-84
18.3.3	Cab electrical top connector location diagram	18-85
18.3.4	Front chassis electrical connector location diagram	18-86
18.3.5	Rear chassis electrical connector location diagram	18-87

18.1 Hydraulic schematics

18.1.1 Implement hydraulic schematic

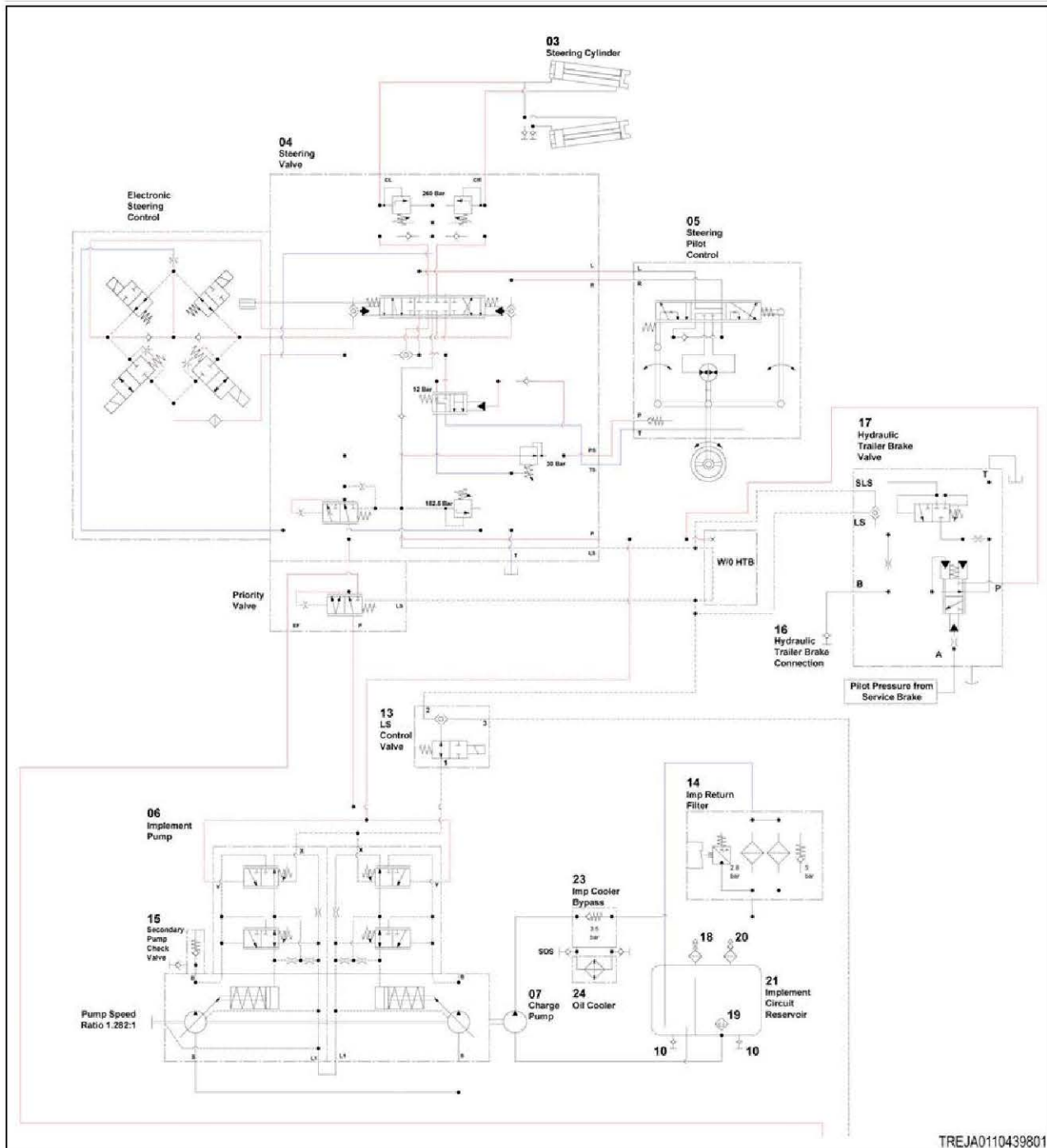

TREJA0110439801

Fig. 1

Item	Schematic term	Description
03	Steering Cylinder	Steering cylinder
04	Steering Valve	Steering valve
05	Steering Pilot Control	Steering pilot control
06	Implement Pump	Implement pump
07	Charge Pump	Charge pump

Item	Schematic term	Description
08	Intermediate Valve Stack	Intermediate valve stack
09	Imp Return Filter	Implement return filter
10	Ecology Drain	Ecology drain
13	LS Control Valve	Load sense control valve
14	Imp Return Filter	Implement return filter
15	Secondary Pump Check Valve	Secondary pump check valve
16	Hydraulic Trailer Brake Connection	Hydraulic trailer brake connection
17	Hydraulic Trailer Brake Valve	Hydraulic trailer brake valve
18	Breather	Breather
19	Strainer	Strainer
20	Breather Cap	Breather cap
21	Implement Circuit Reservoir	Implement circuit reservoir
23	Imp Cooler Bypass	Implement cooler bypass
24	Oil Cooler	Oil cooler
-	Electronic Steering Control	Electronic steering control
-	W/O HTB	Without hydraulic trailer brake
-	Priority Valve	Priority valve
-	Pump Speed Ratio	Pump speed ratio
-	SOS	Silicon on sapphire check valve

18.1.2 Implement valve configuration schematic (drawbar)

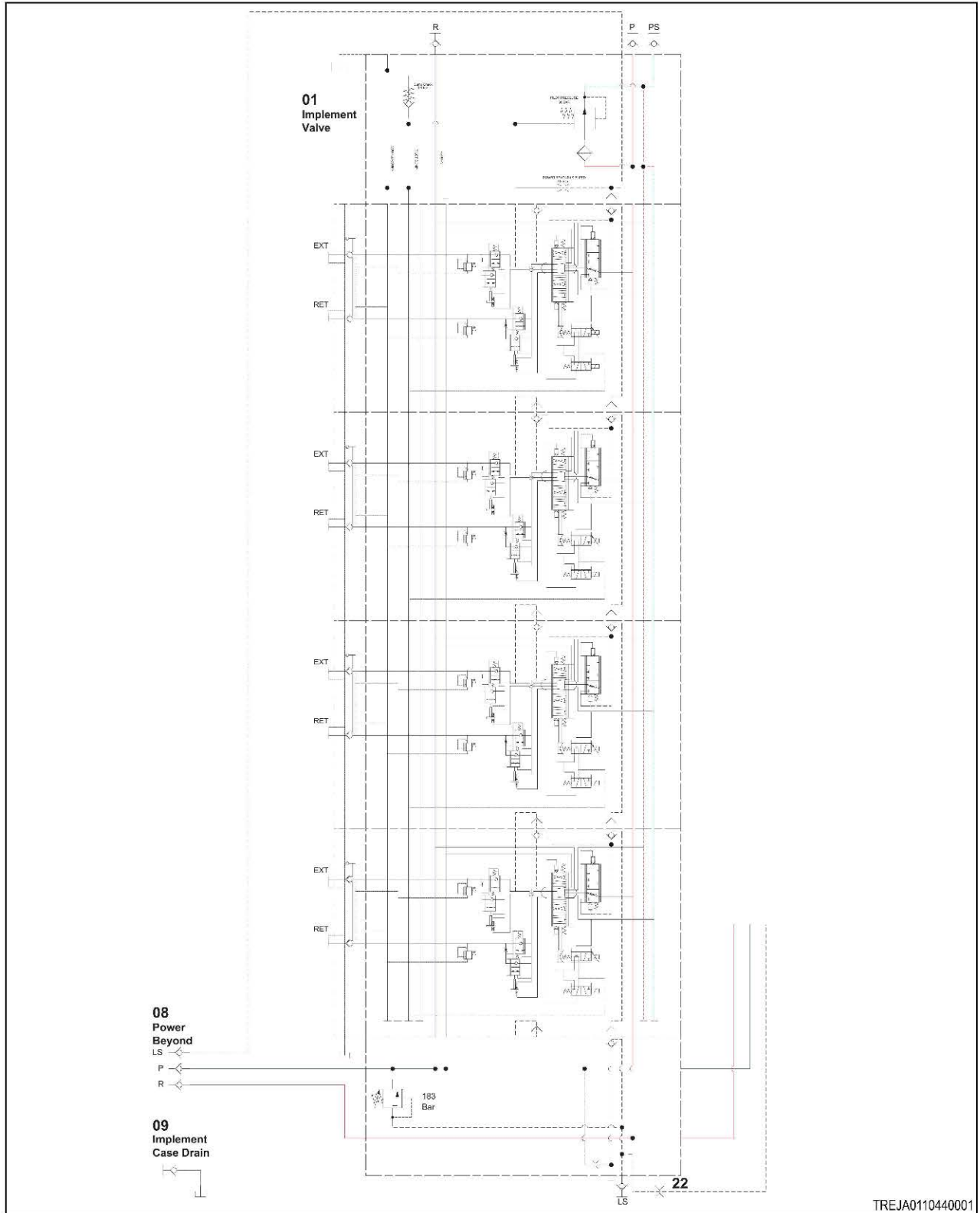

Fig. 2

TREJA0110440001

Item	Schematic term	Description
01	Implement Valve	Implement valve
08	Power Beyond	Power beyond
09	Implement Case Drain	Implement case drain
-	Sump Check 3.5 bar (50 psi)	Sump check valve
-	COUPLER SUMP	Coupler sump
-	PILOT SUMP	Pilot sump
-	RETURN	Return
-	EXT	Extend
-	RET	Retract
-	PILOT PRESSURE 30 bar (435 psi)	Pilot pressure
-	Power Beyond LS Bleed	Power beyond load sense bleed

18.1.3 Implement valve configuration schematic (3-point linkage)

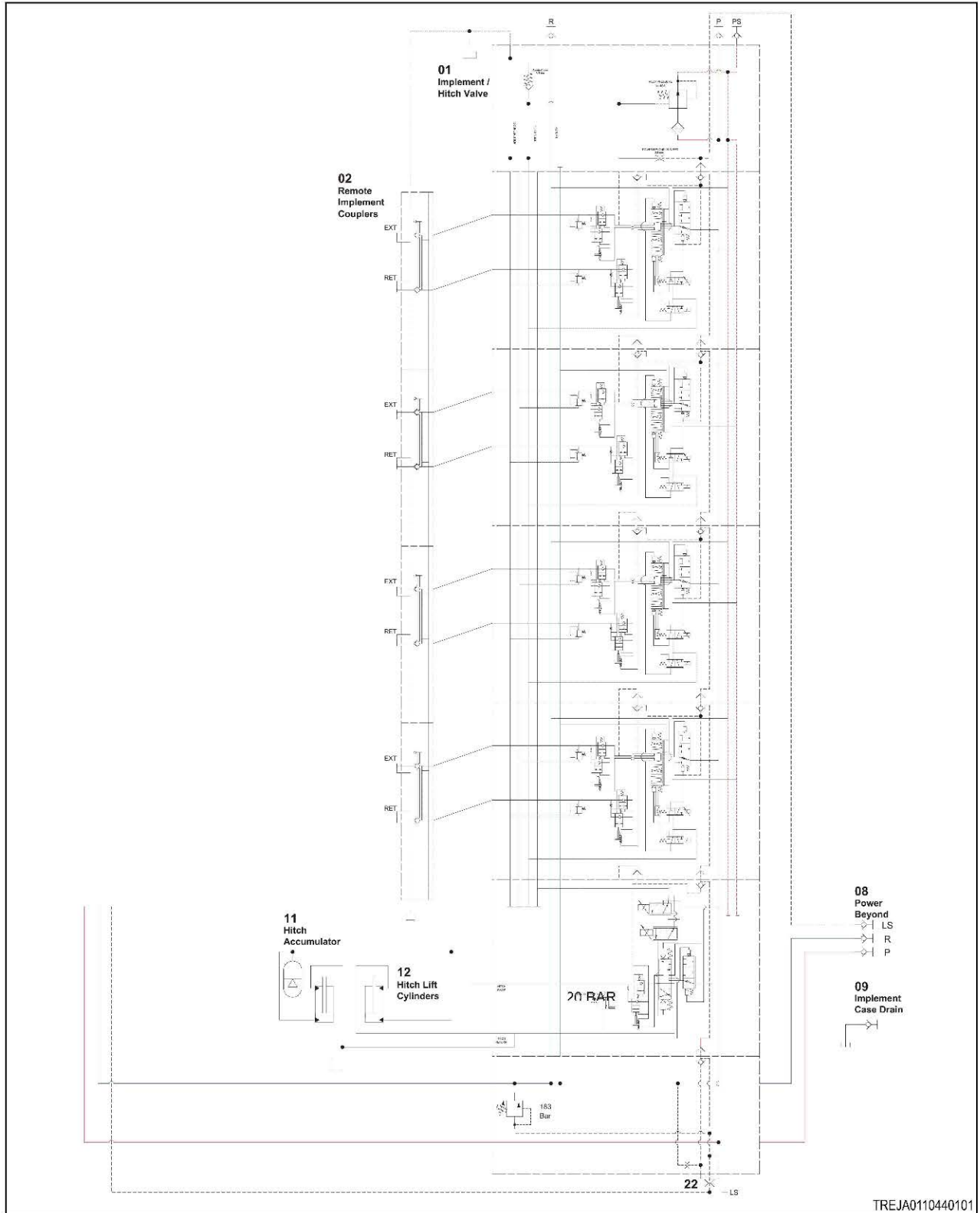
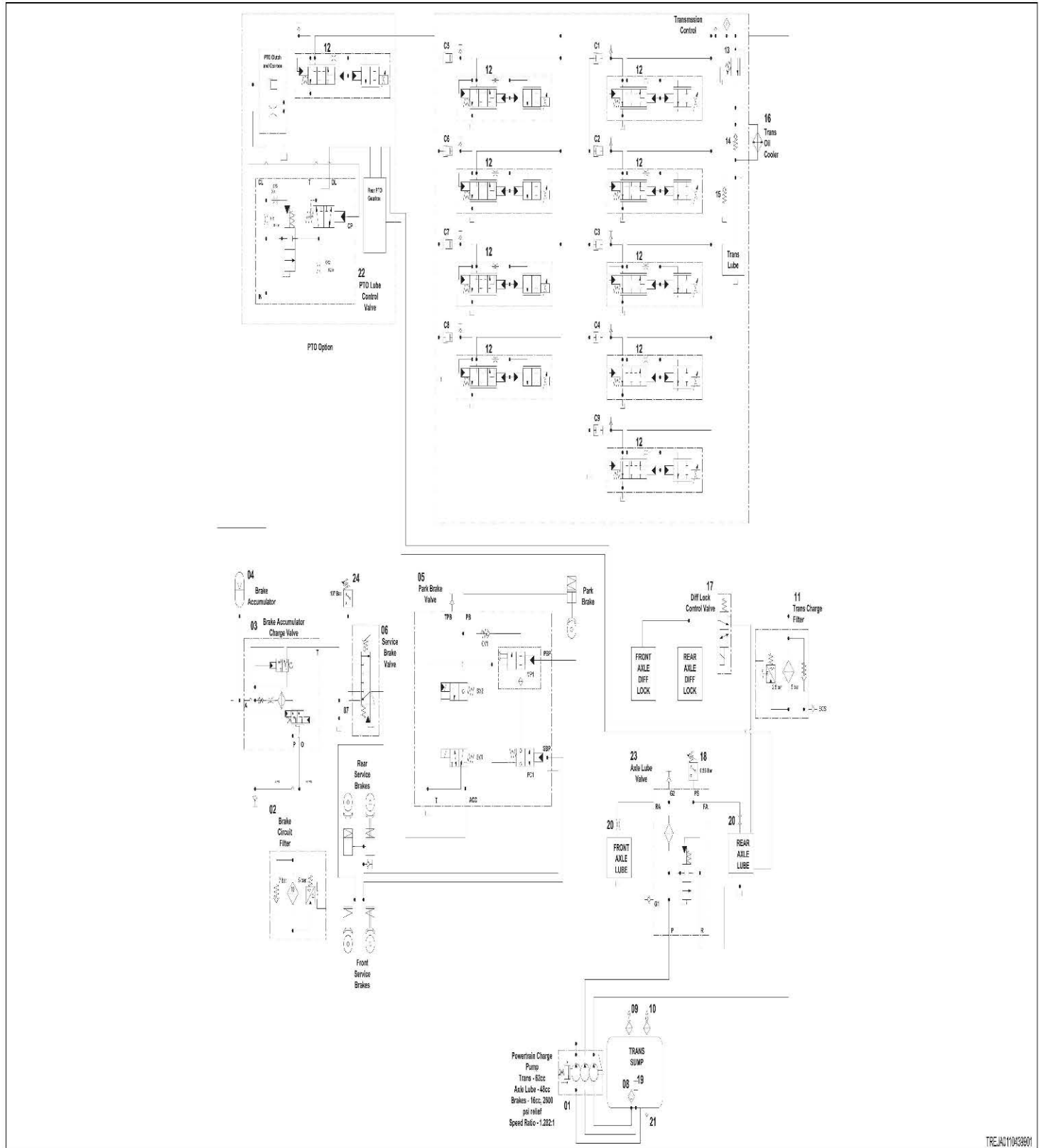

Fig. 3

Item	Schematic term	Description
01	Implement/Hitch Valve	Implement/linkage valve
02	Remote Implement Couplers	Remote implement couplers
08	Power Beyond	Power beyond
09	Implement Case Drain	Implement case drain
11	Hitch Accumulator	Linkage accumulator
12	Hitch Lift Cylinders	Lift cylinders
-	Sump Check 3.5 bar (50 psi)	Sump check valve
-	COUPLER SUMP	Coupler sump
-	PILOT SUMP	Pilot sump
-	RETURN	Return
-	EXT	Extend
-	RET	Retract
-	PILOT PRESSURE 30 bar (435 psi)	Pilot pressure
-	Power Beyond LS Bleed	Power beyond load sense bleed

18.1.4 Drive train hydraulic schematic



TREJA110436901

Item	Schematic term	Description
01	Powertrain Charge Pump	Tri-section pump
02	Brake Circuit Filter	Brake circuit filter
03	Brake Accumulator Charge Valve	Brake accumulator charge valve
04	Brake Accumulator	Brake accumulator
05	Park Brake Valve	Park brake valve
06	Service Brake Valve	Service brake valve
07	Check Valve	Check valve
08	Screen	Screen
09	Breather	Breather
10	Breather Cap	Breather cap
11	Trans Charge Filter	Transmission charge filter
12	VALVE GP-MDLC	Modulating valve
13	VALVE GP-RELIEF	Relief valve
14	VALVE-RELIEF	Relief valve
15	VALVE-RELIEF	Relief valve
16	Trans Oil Cooler	Transmission oil cooler
17	Diff Lock Control Valve	Differential lock control valve
18	Pressure Switch	Pressure switch
19	Axle Lube Standpipe	Axle lubrication standpipe assembly
20	Adapter	Adapter
21	Ecology Drain	Ecology drain
22	PTO Lube Control Valve	Power take-off lube control valve
23	Axle Lube Valve	Axle lubrication valve
24	Pressure Switch	Pressure switch
-	Front Service Brakes	Front service brakes
-	Rear Service Brakes	Rear service brakes
-	TRANS SUMP	Transmission sump
-	FRONT AXLE LUBE	Front axle lubrication
-	REAR AXLE LUBE	Rear axle lubrication
-	FRONT AXLE DIFF LOCK	Front axle differential lock
-	REAR AXLE DIFF LOCK	Rear axle differential lock
-	Trans - 62cc	Transmission - 62cc
-	Axle Lube - 48cc	Axle lubrication - 48cc
-	Brakes - 16cc	Brakes - 16cc
-	PTO Option	Power take-off option
-	Transmission Control	Transmission control

Item	Schematic term	Description
-	PTO Clutch and Gearbox	Power take-off clutch and gearbox
-	Trans Lube	Transmission lubrication
-	Rear PTO Gearbox	Rear power take-off gearbox

18.2 Electrical schematics

18.2.1 MT900E cab schematic

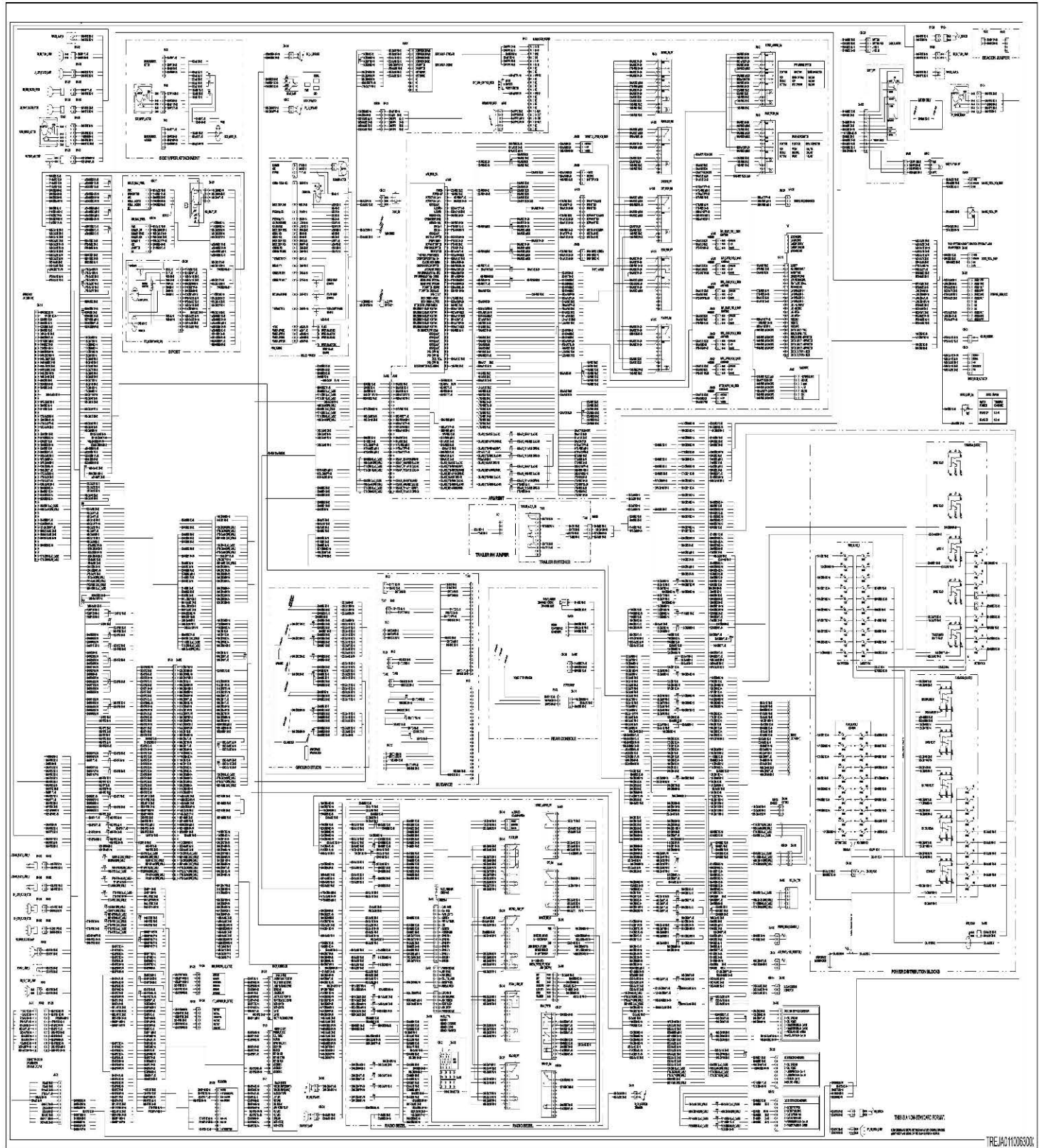

Fig. 5

18.2.2 MT900E chassis schematic

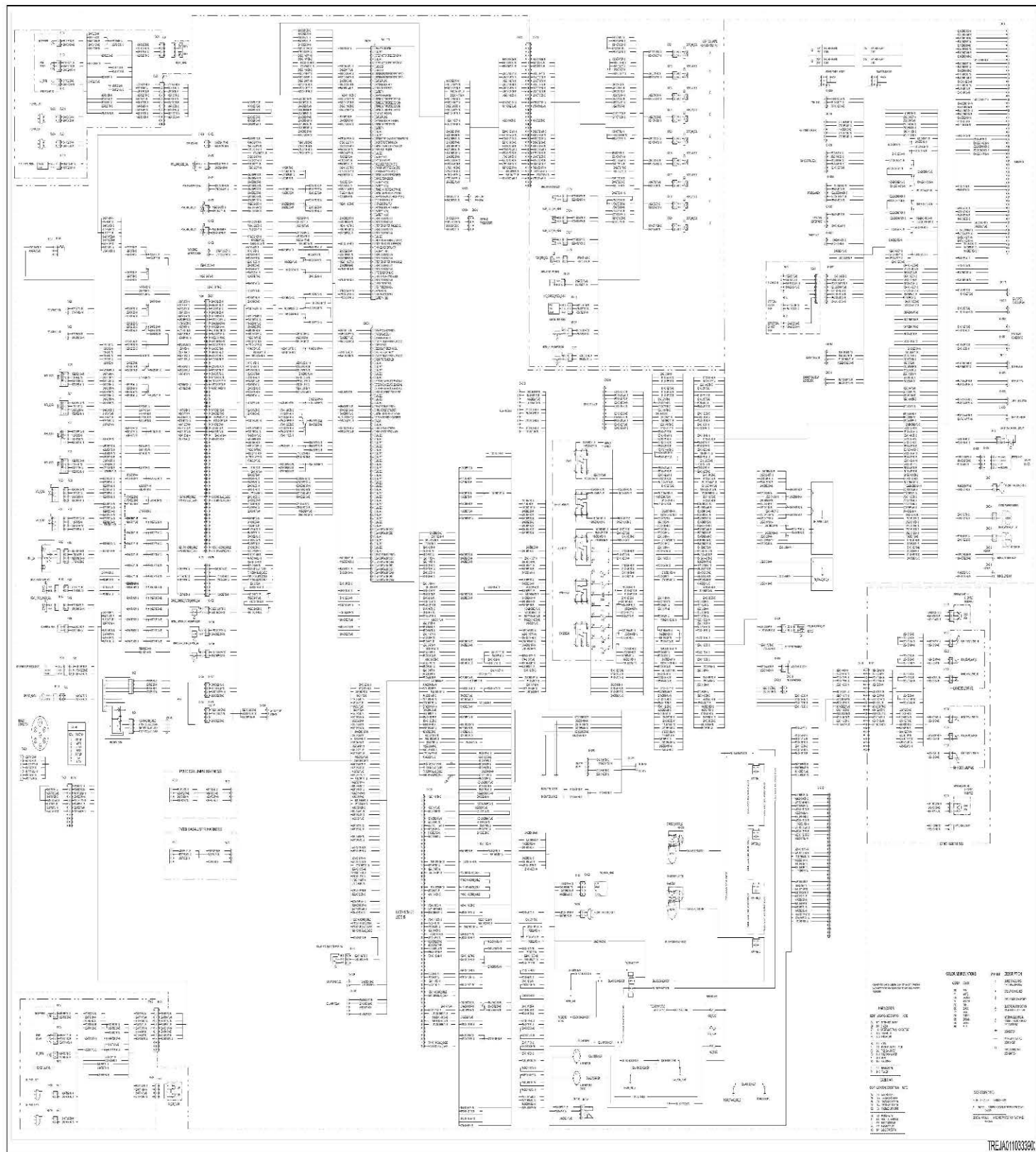

Fig. 6

18.2.3 Throttle lever position sensor

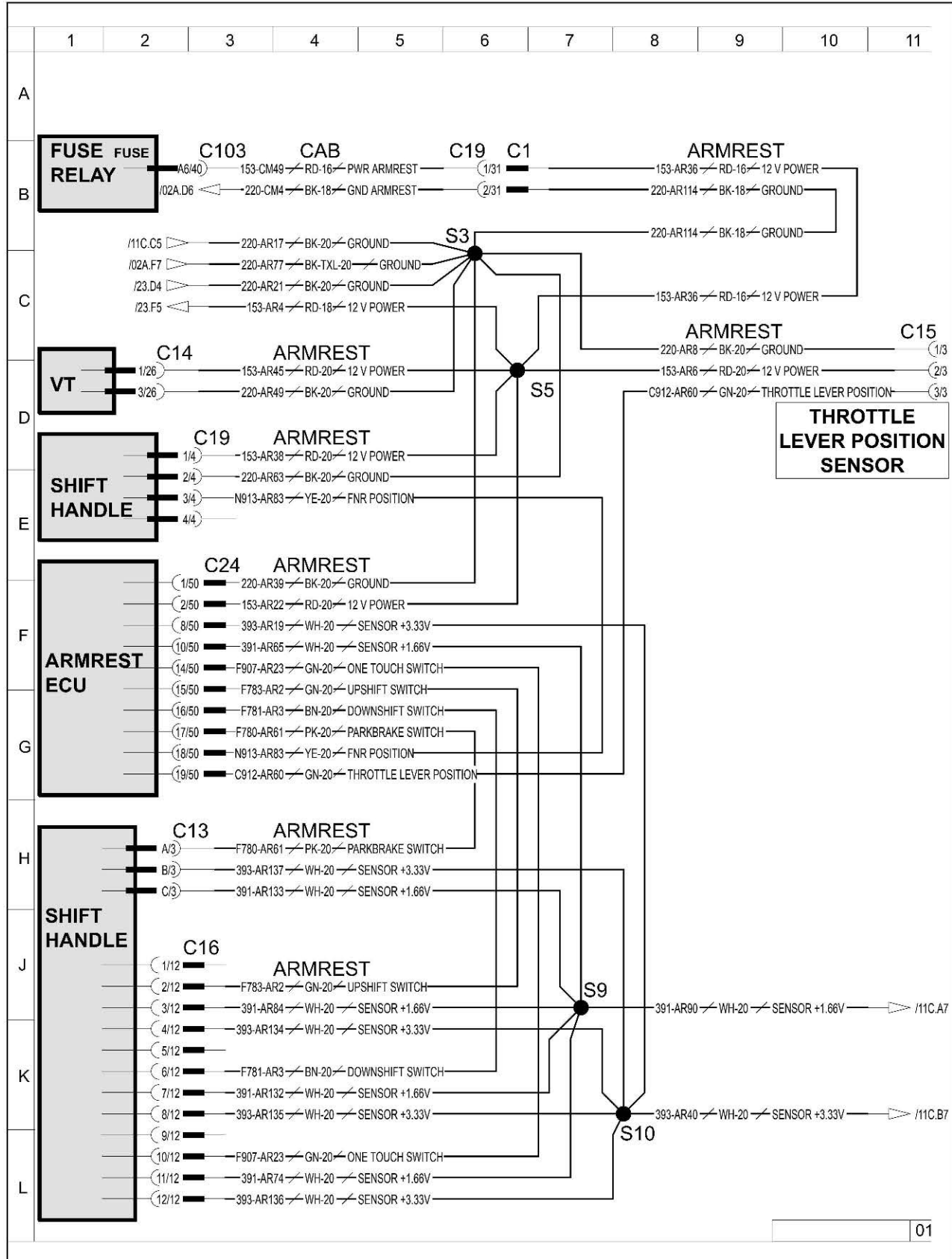

Fig. 7

18.2.4 Rear PTO switch

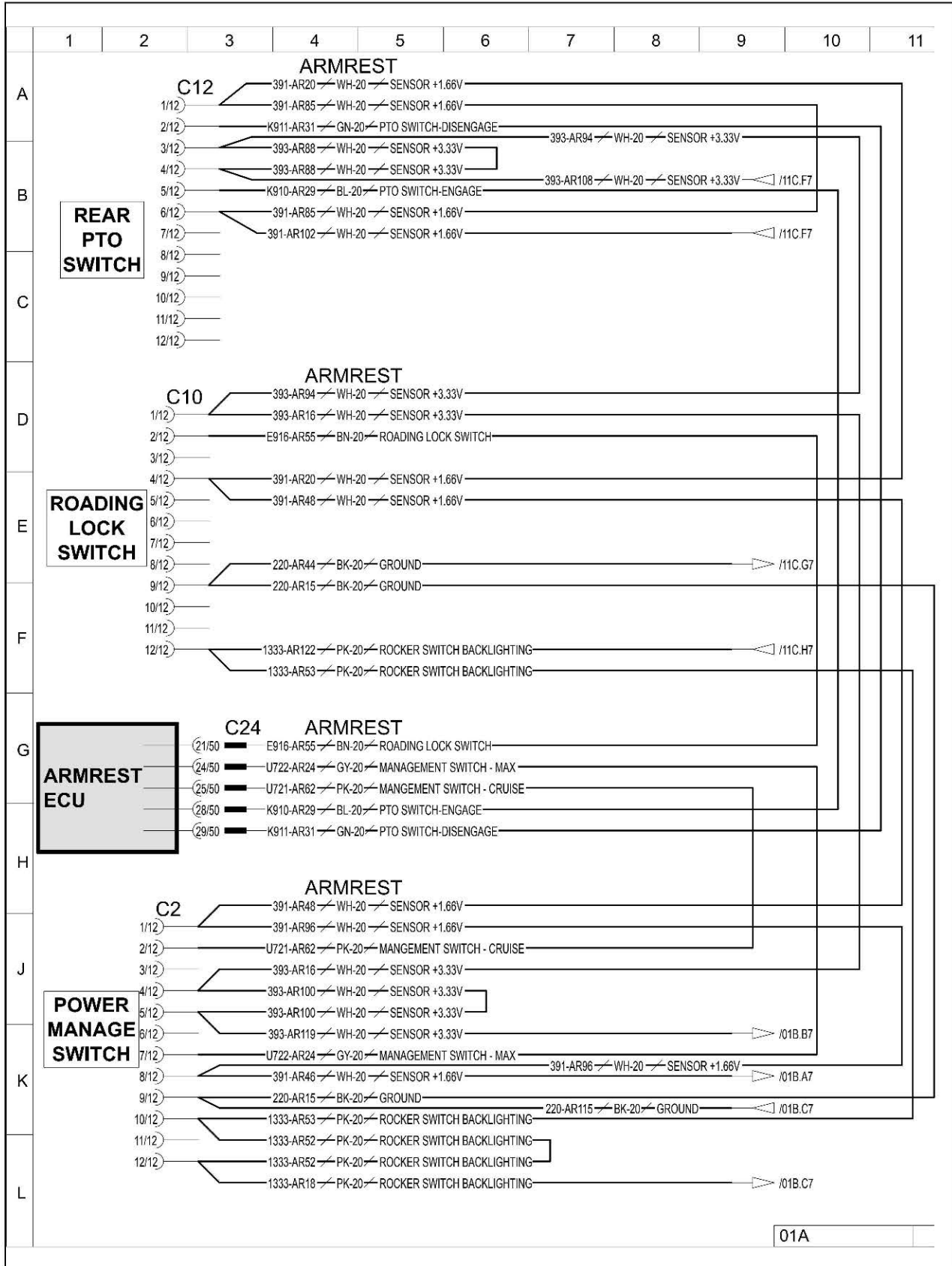

Fig. 8

18.2.5 Raise work switch

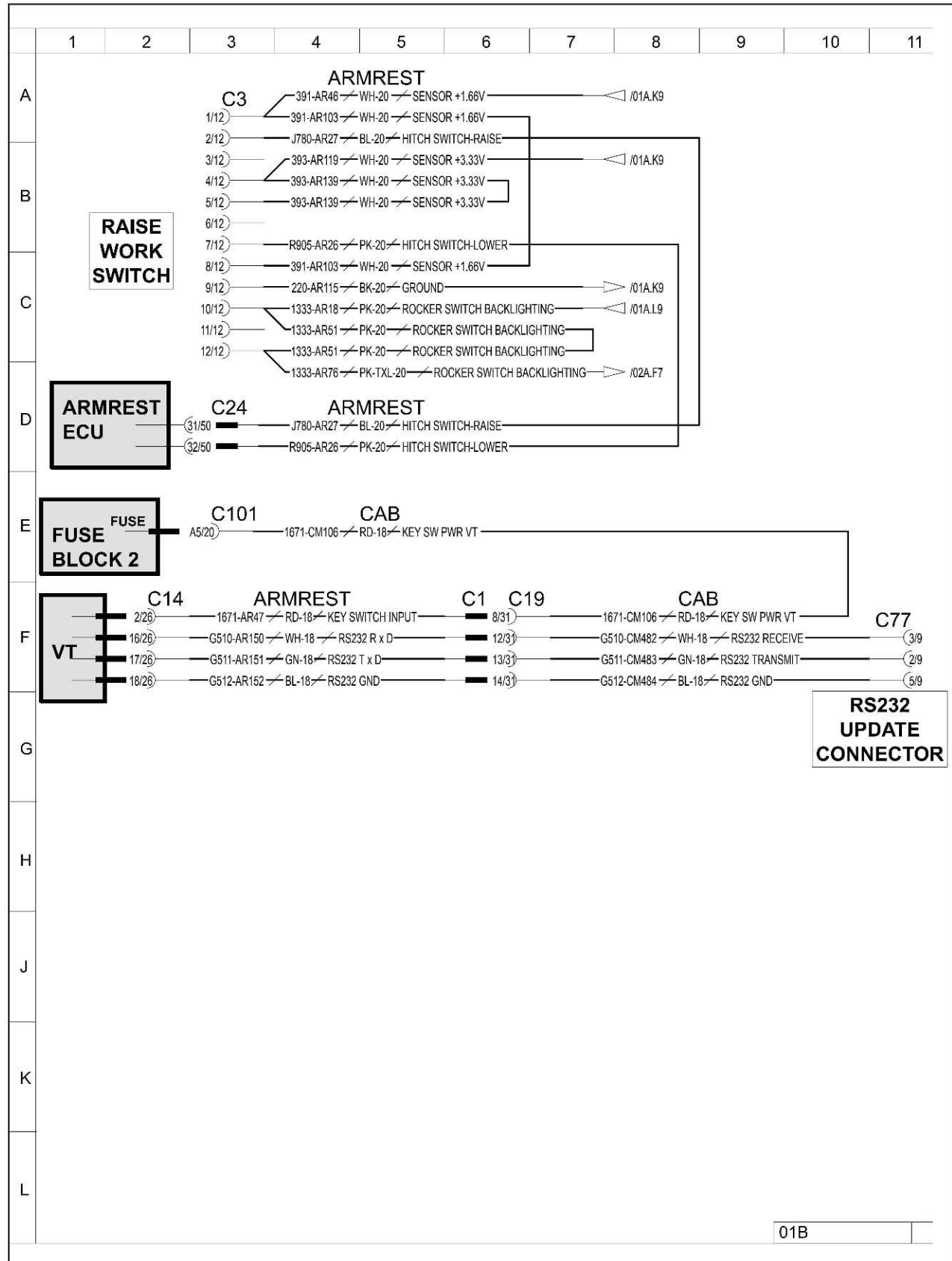

Fig. 9

18.2.6 Topcon X-30

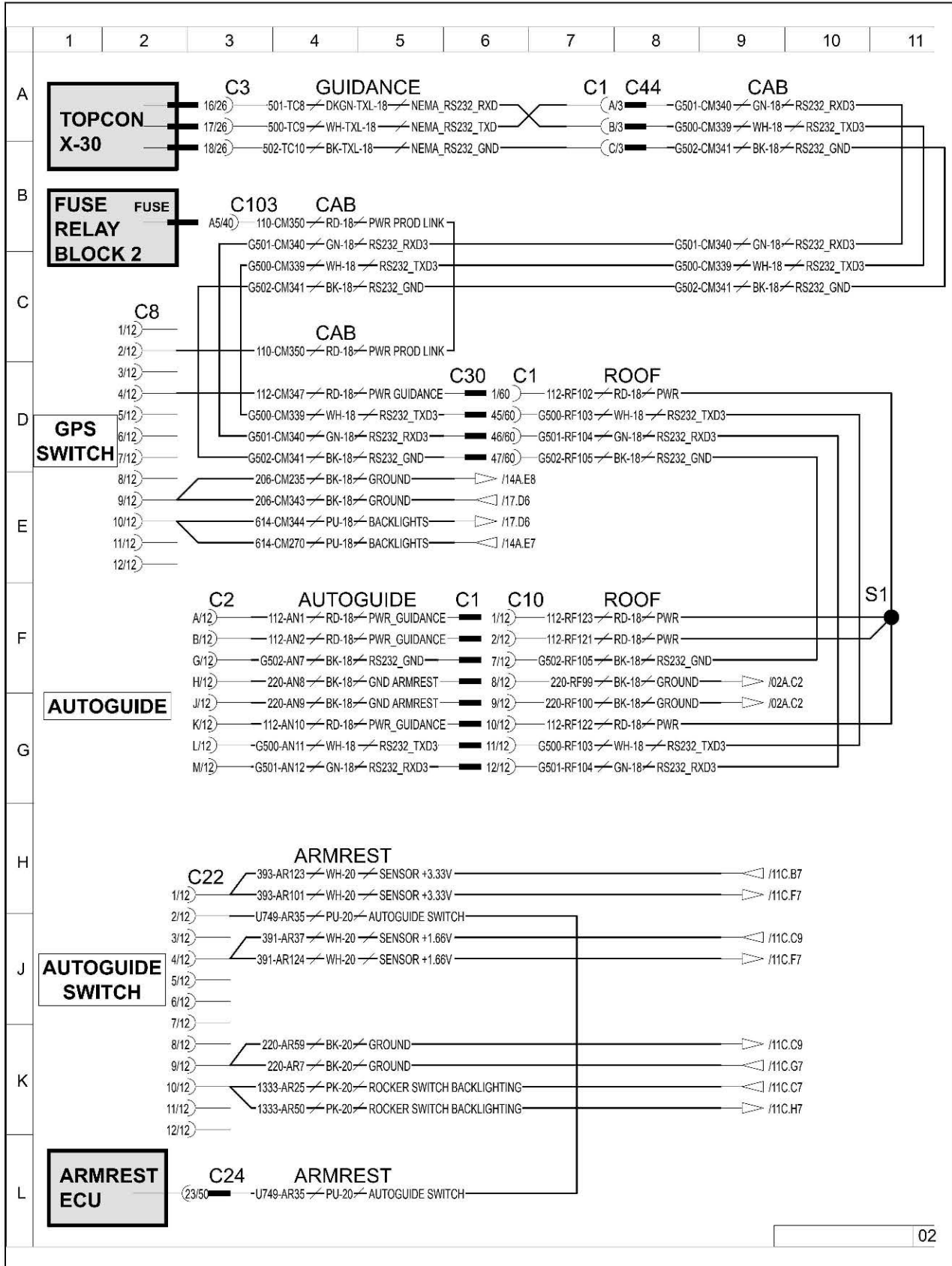

Fig. 10

18.2.7 Armrest 1

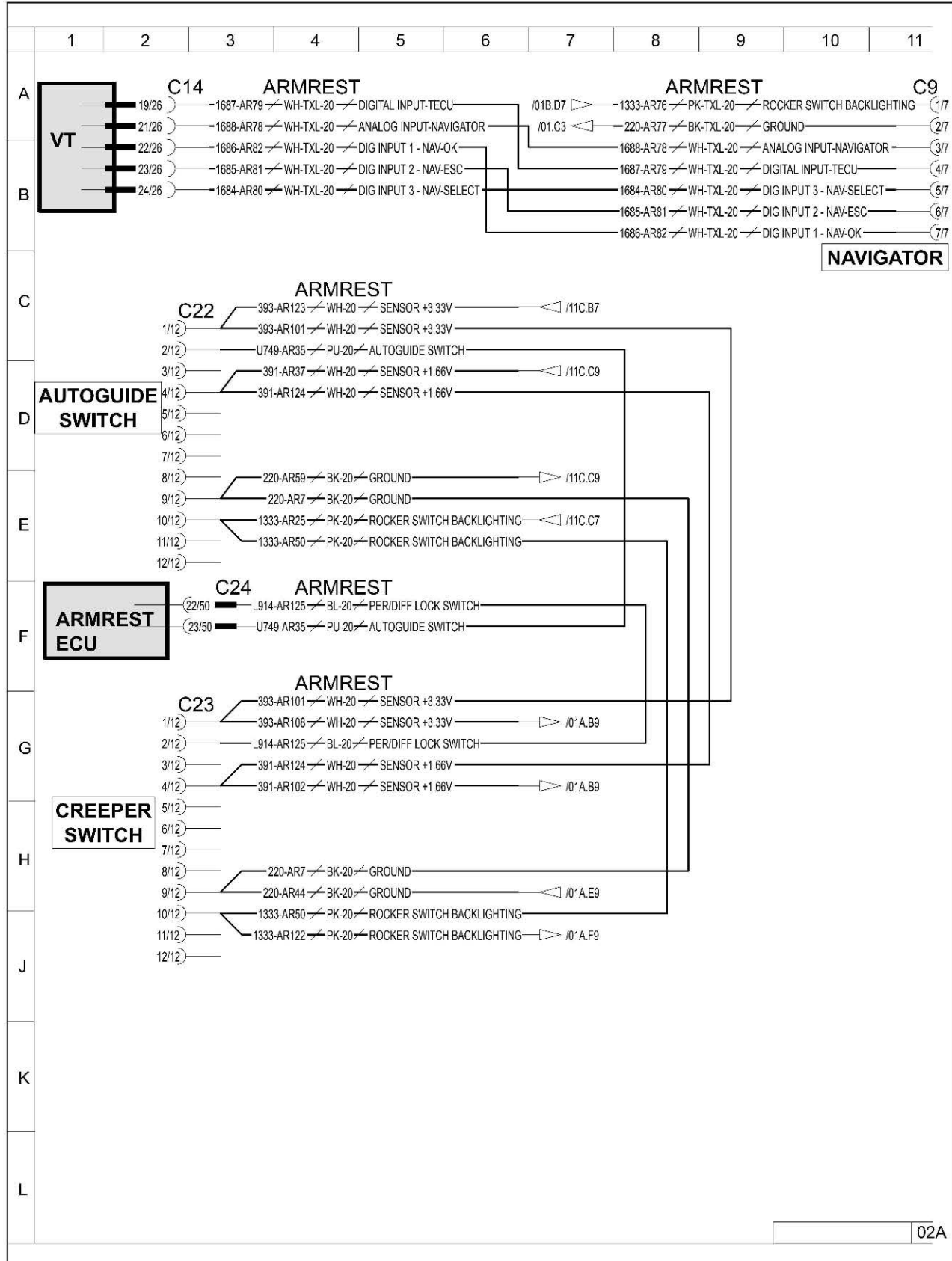

Fig. 11

18.2.8 Roof controller

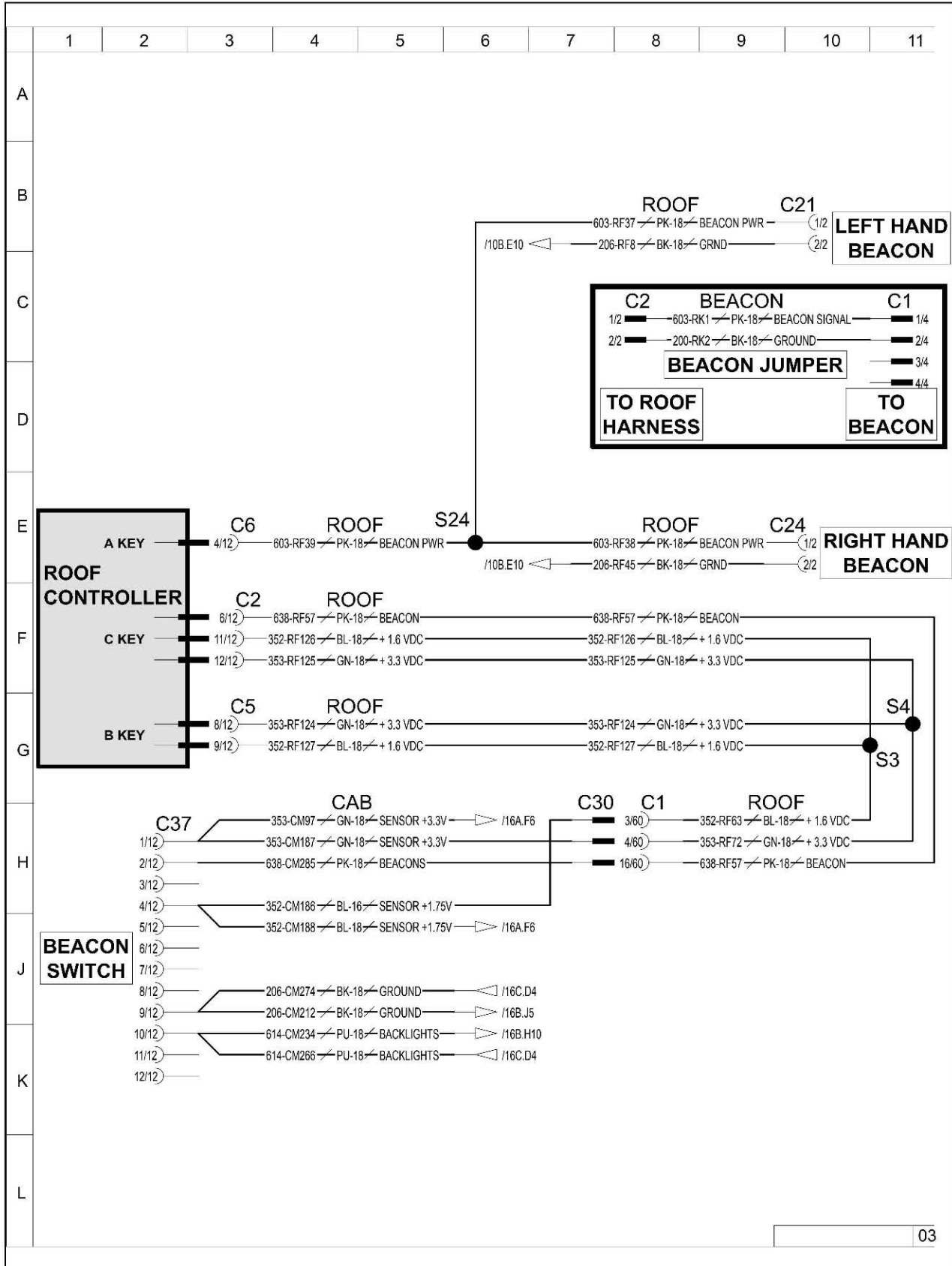

Fig. 12

18.2.9 Park brake

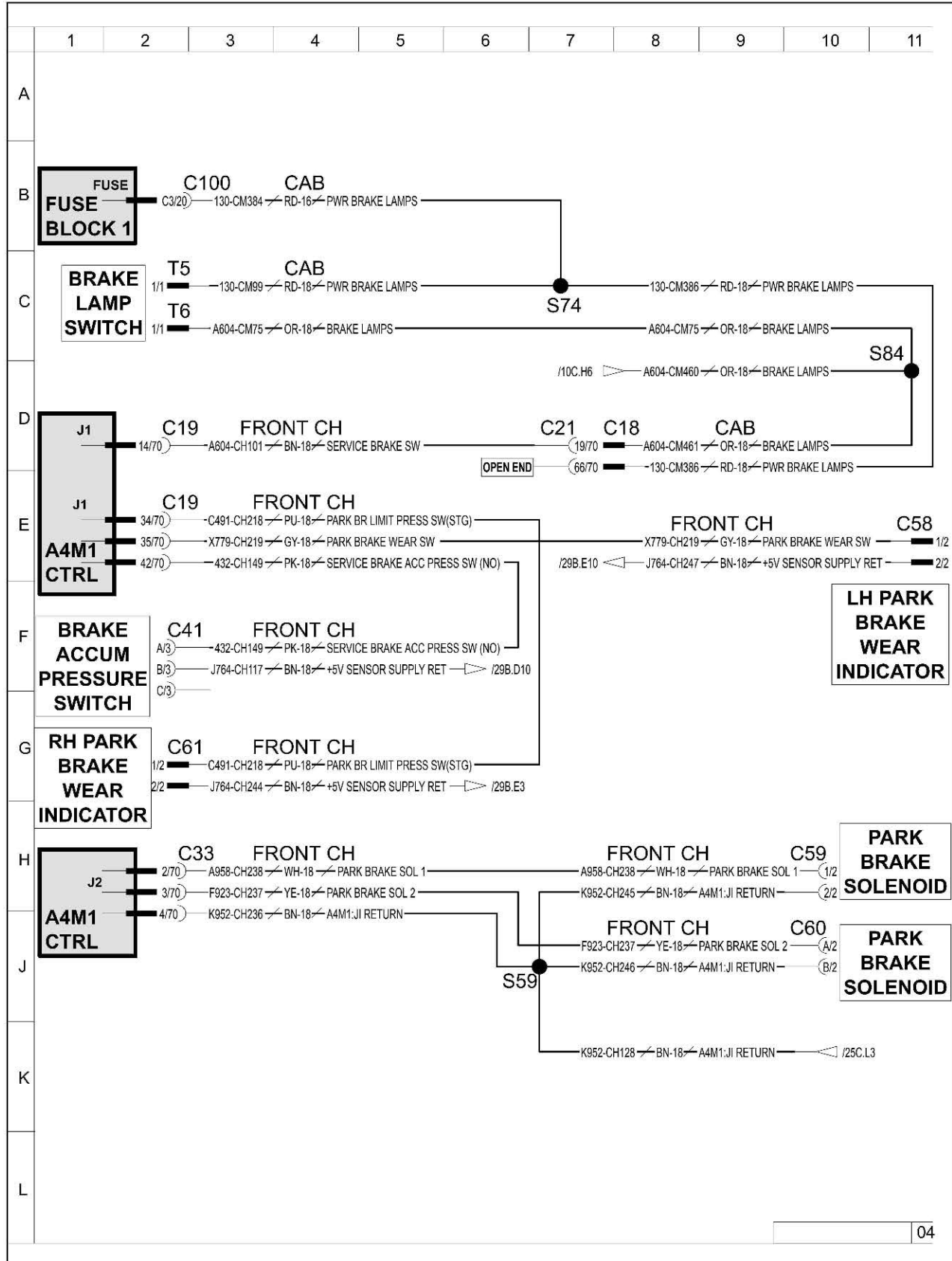

Fig. 13

18.2.10 Engine control module 1

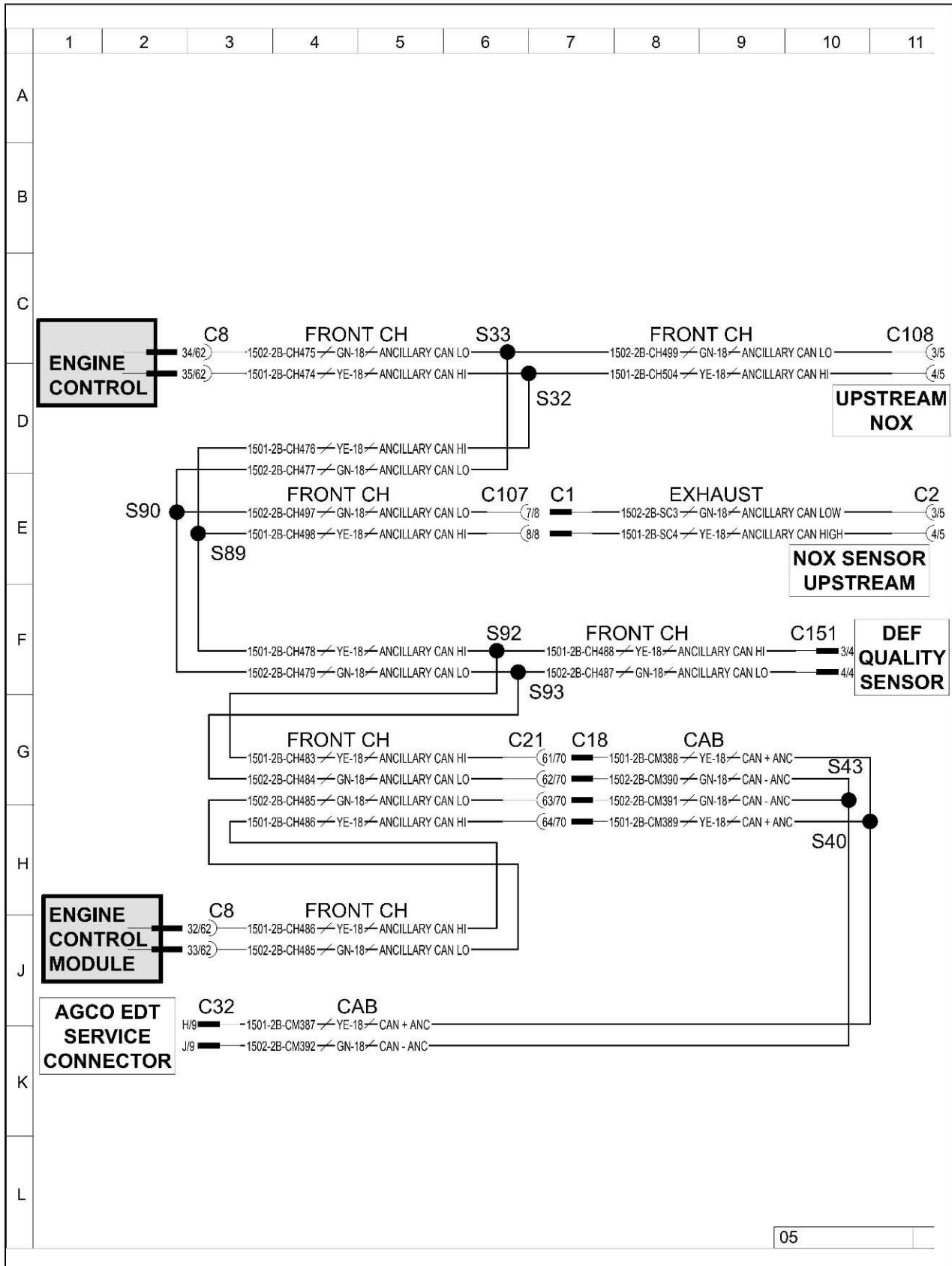

Fig. 14

18.2.12 Dash cluster

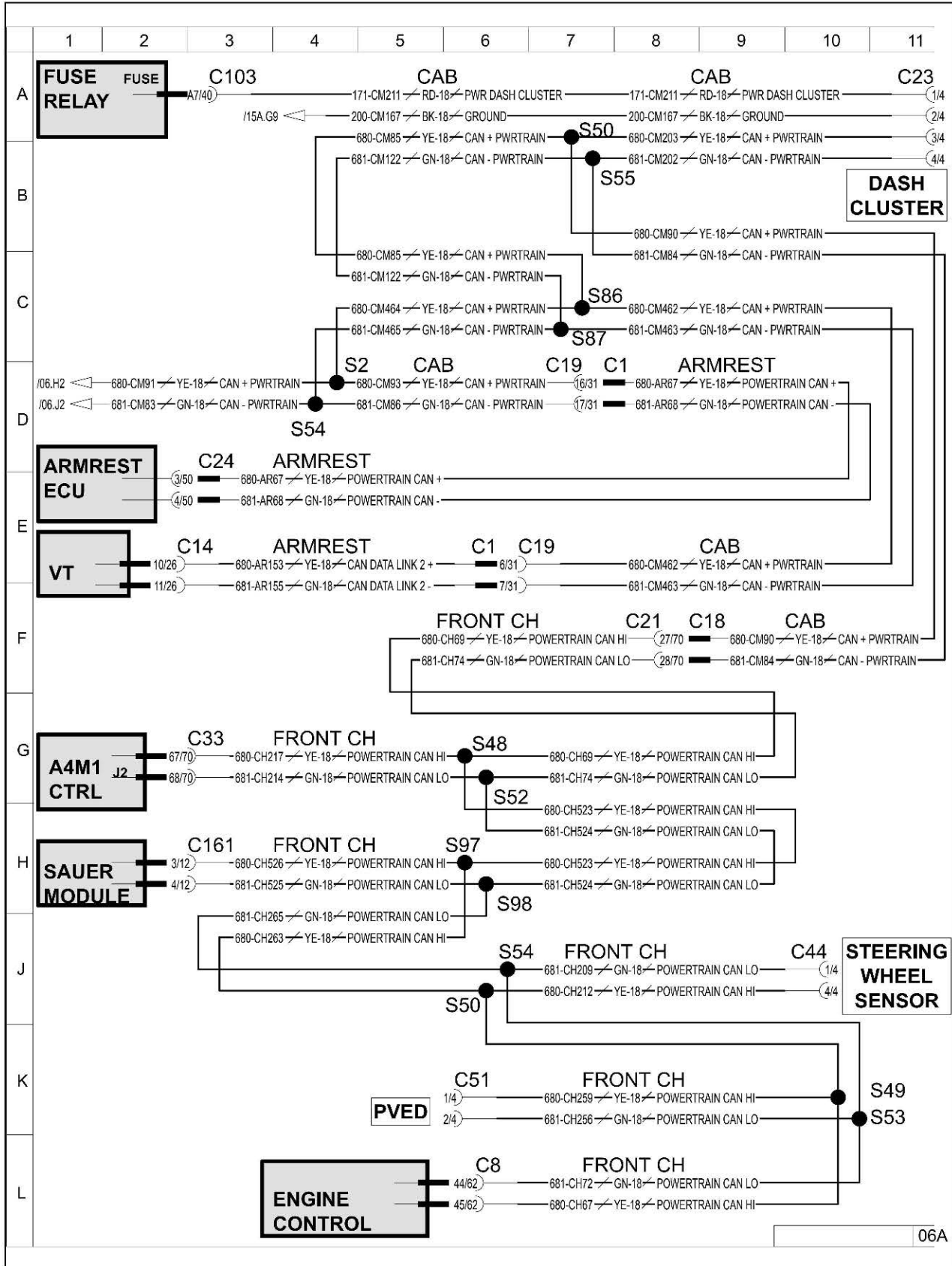

Fig. 16

18.2.13 Implement solenoids

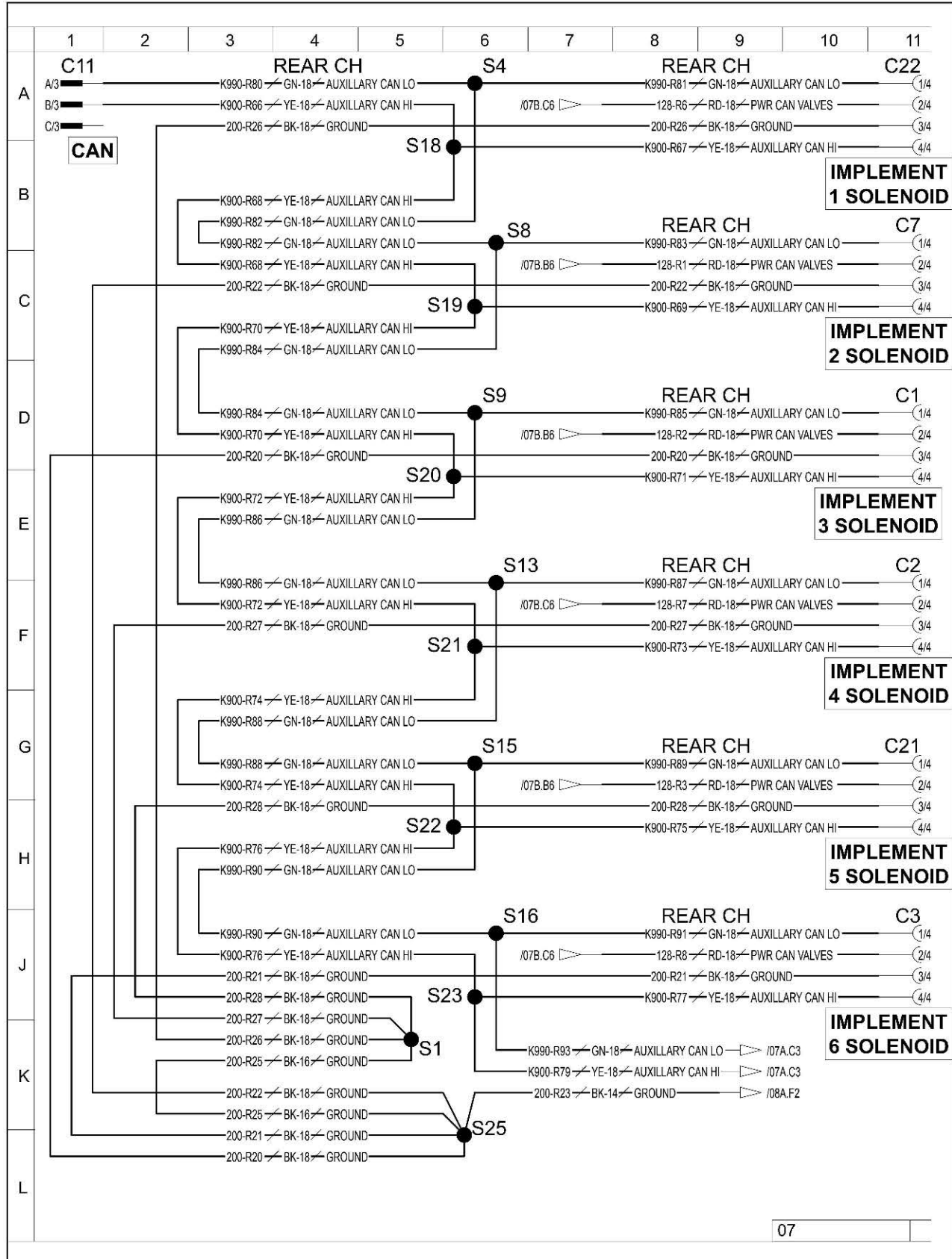

Fig. 17

18.2.14 Front and rear lighting

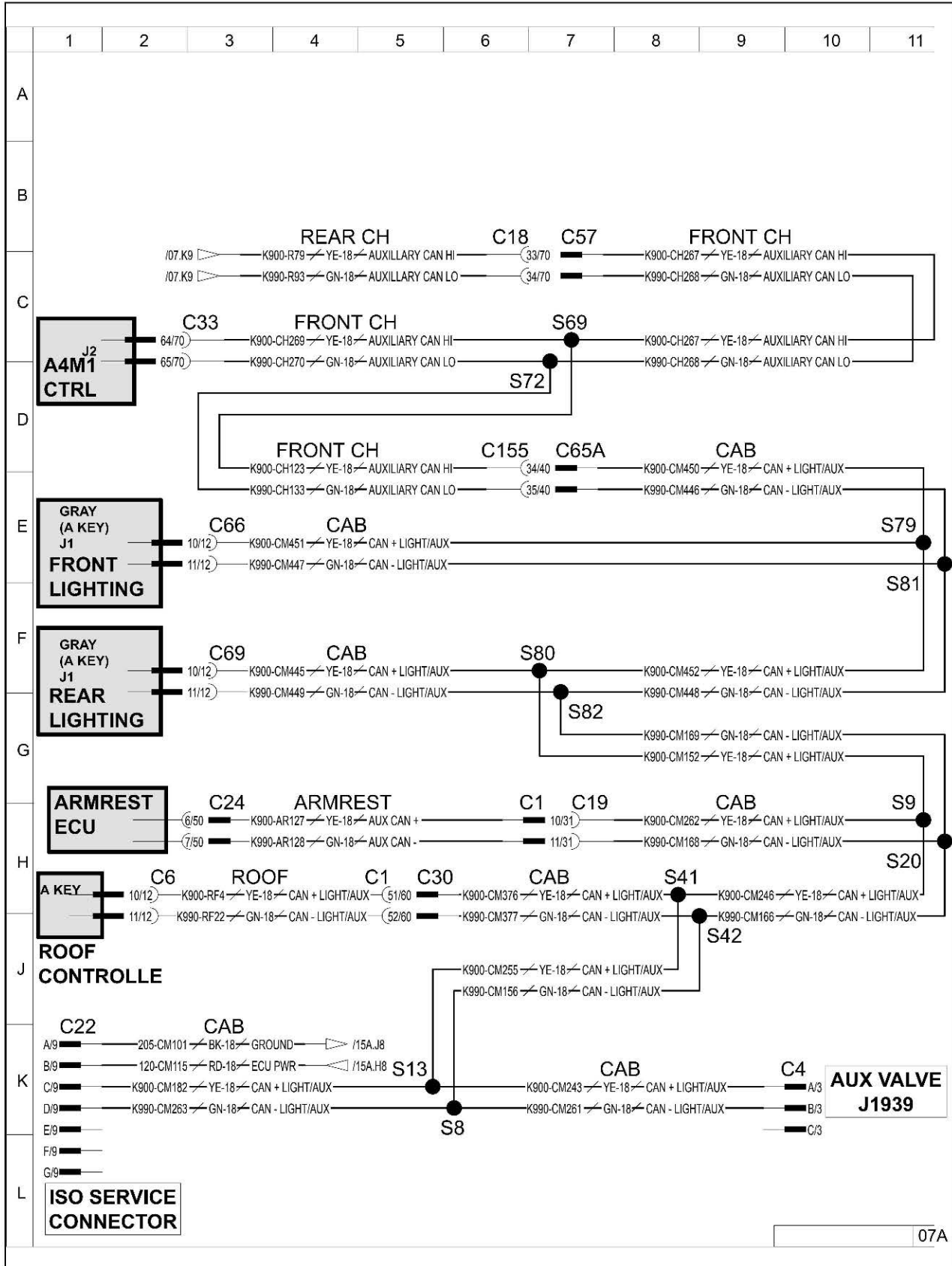

Fig. 18

18.2.15 Fuse block 2

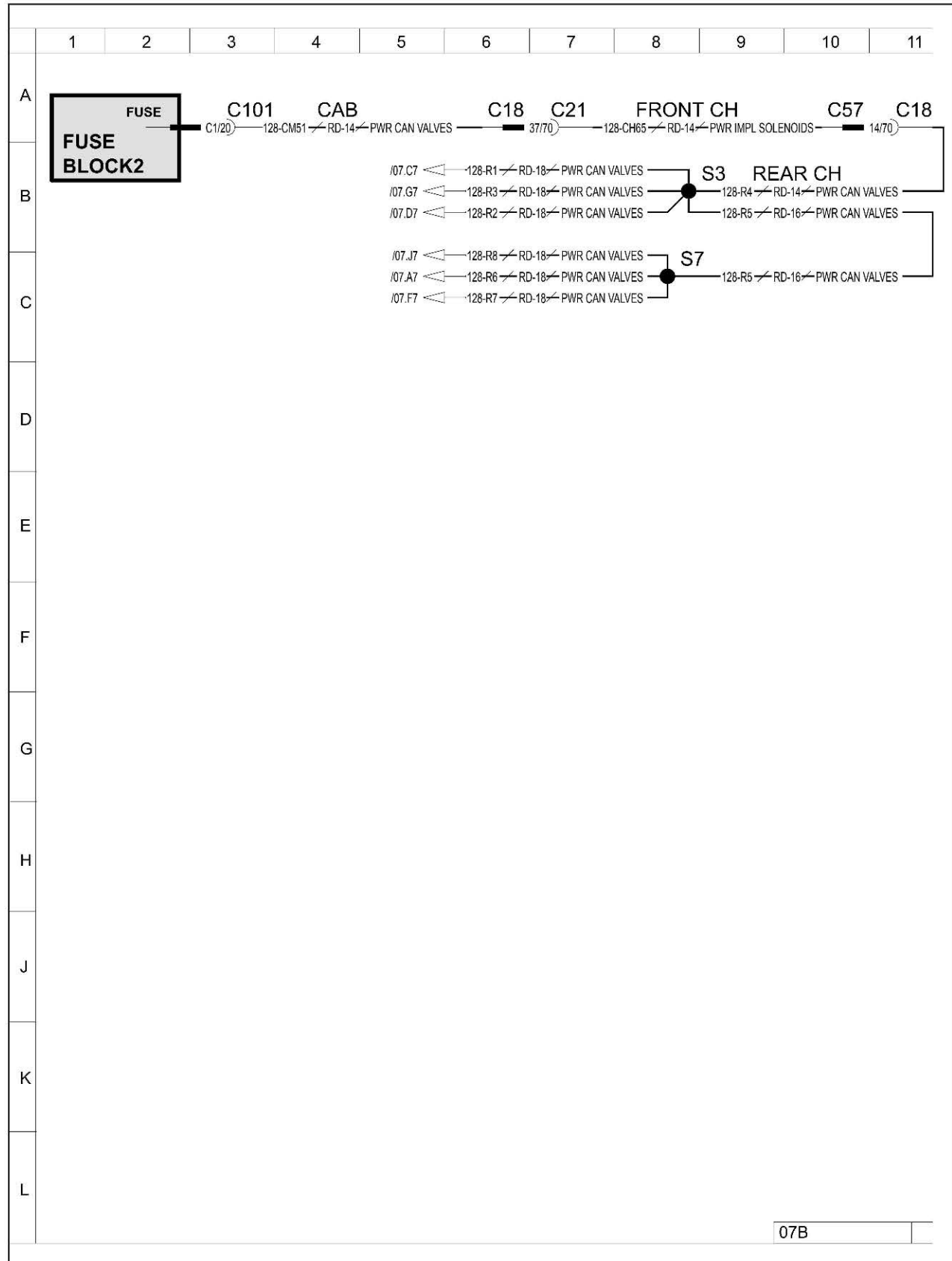

Fig. 19

18.2.16 ISO service connector

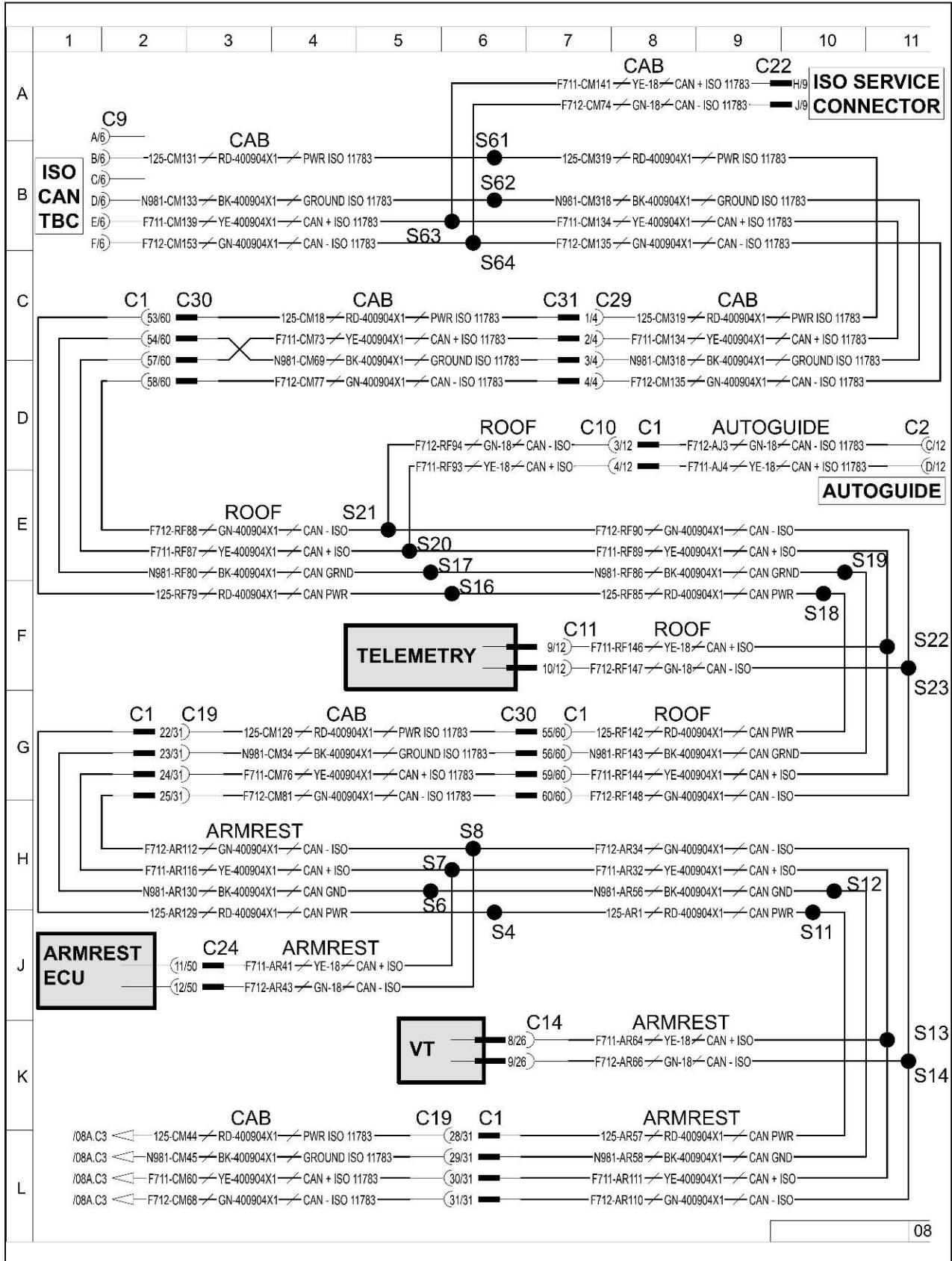

Fig. 20

18.2.17 ISO implement connector

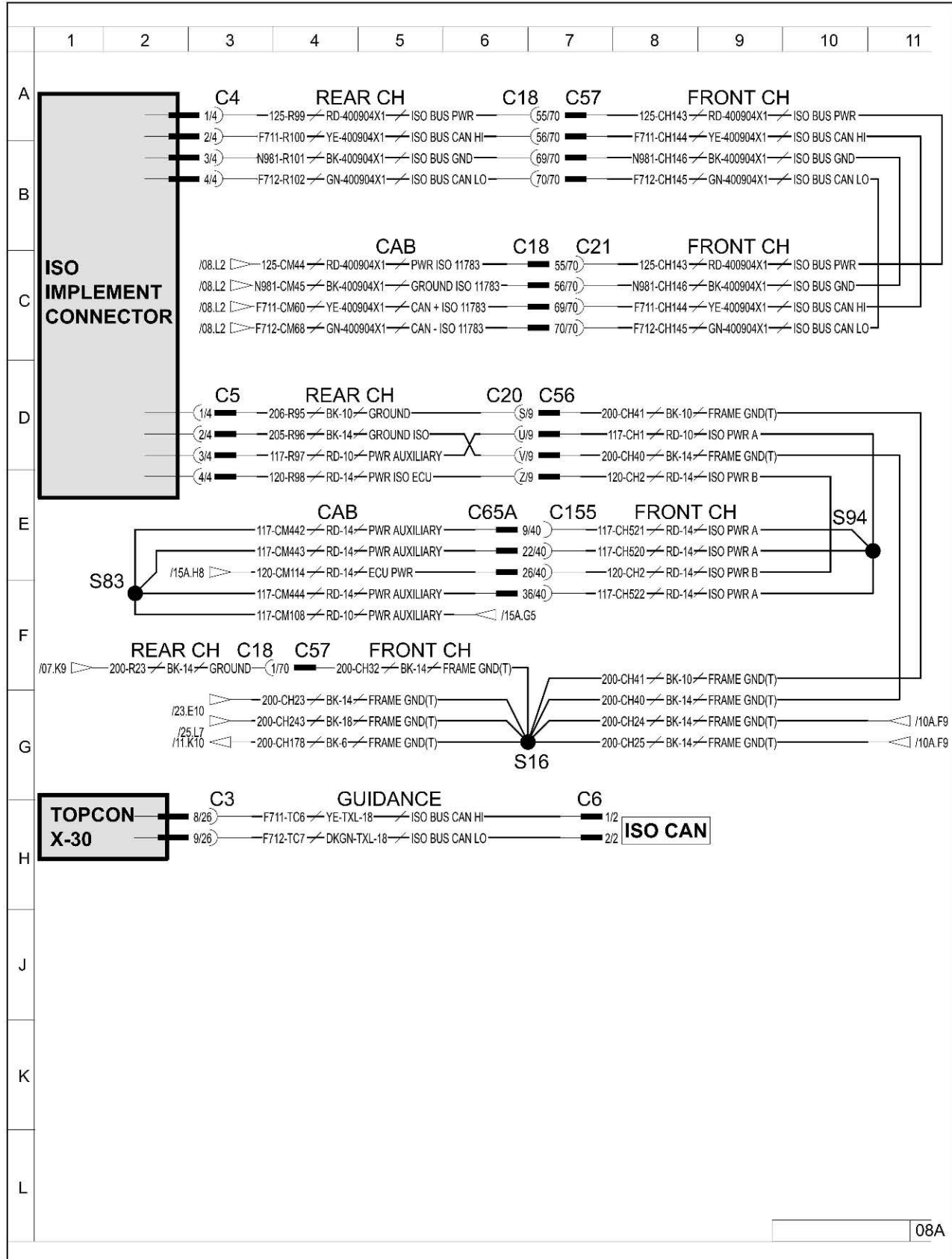
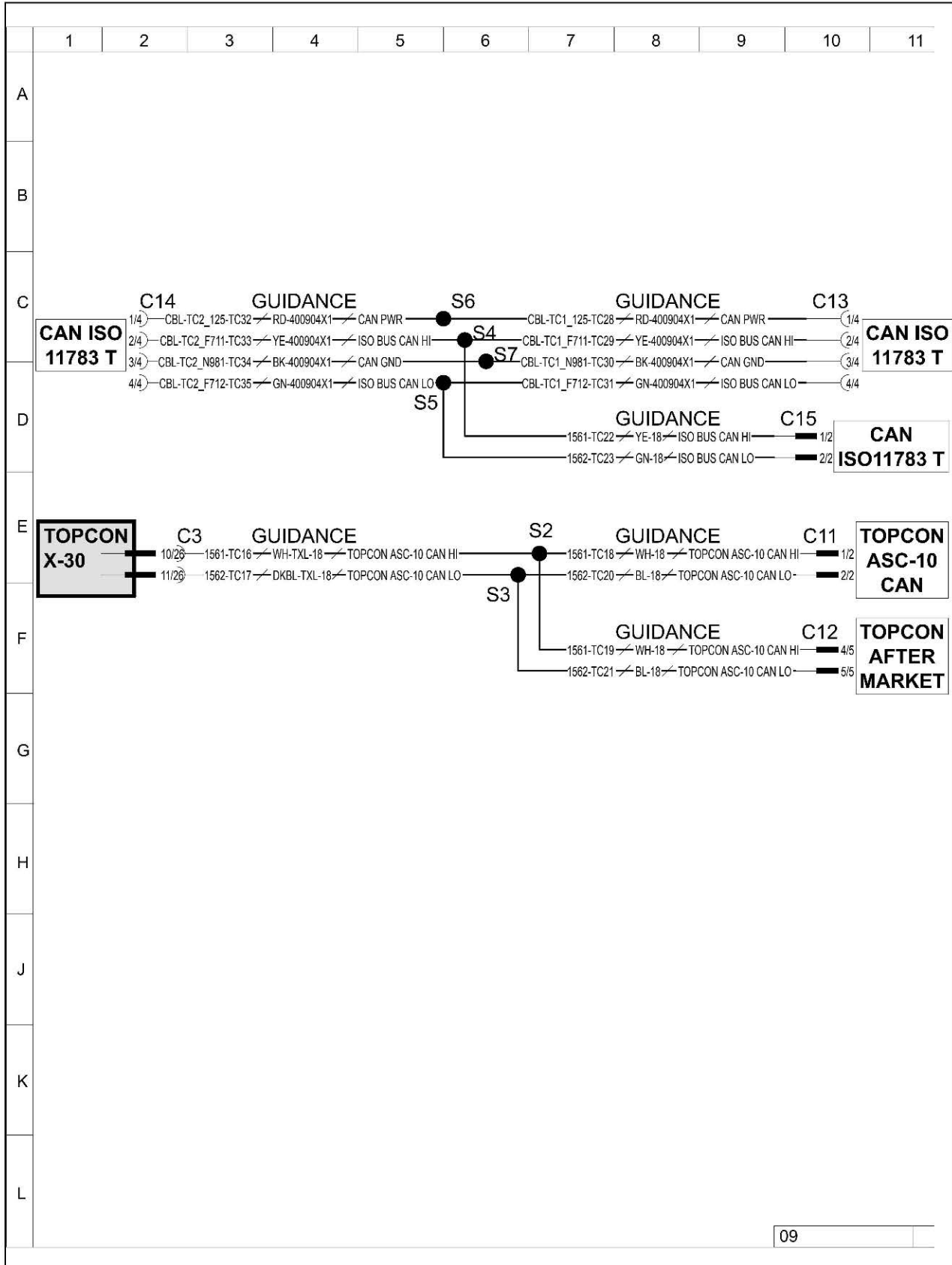

Fig. 21

18.2.18 Guidance



09

Fig. 22

18.2.19 Front lighting ECU

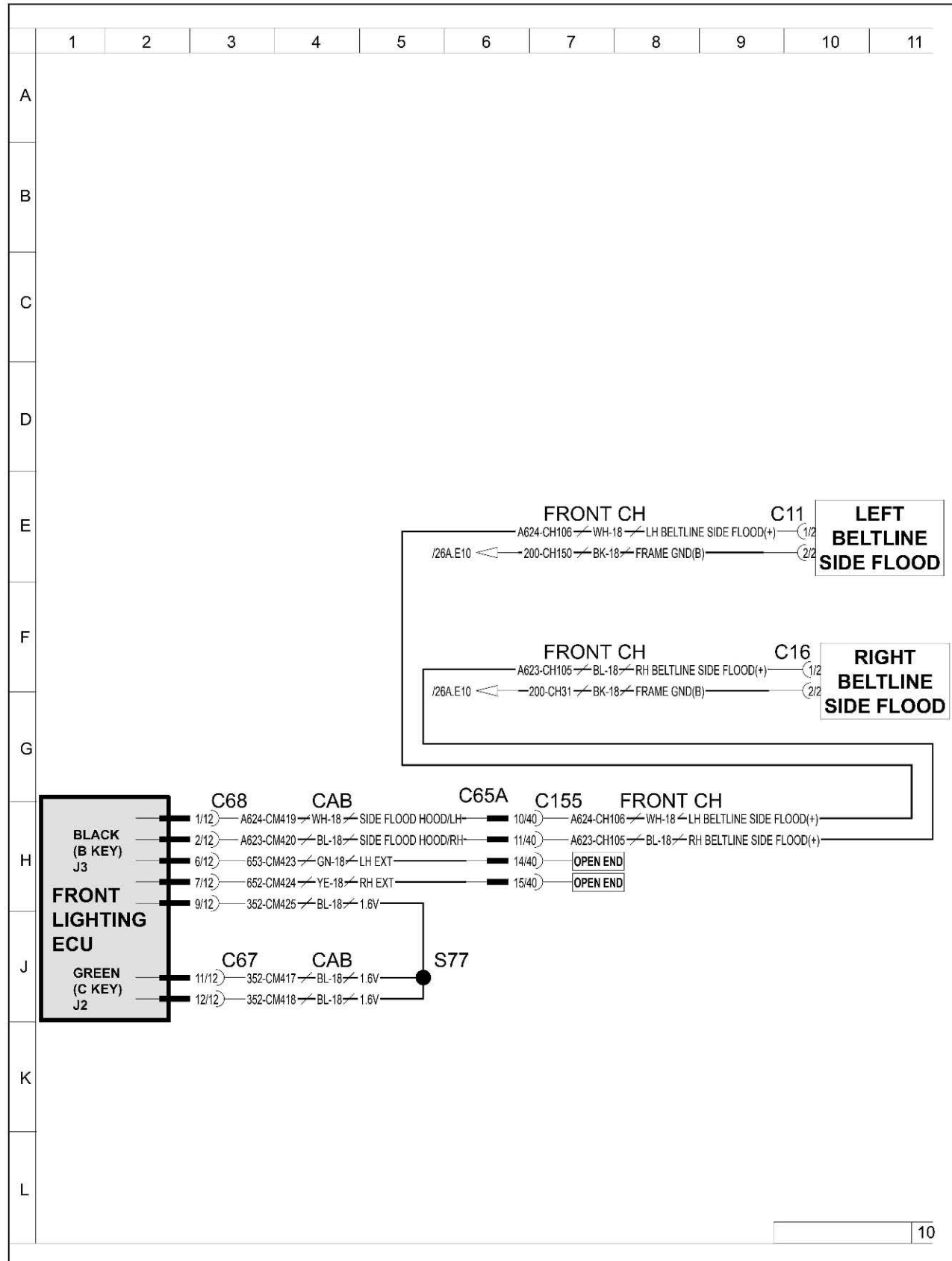

Fig. 23

18.2.22 Cab

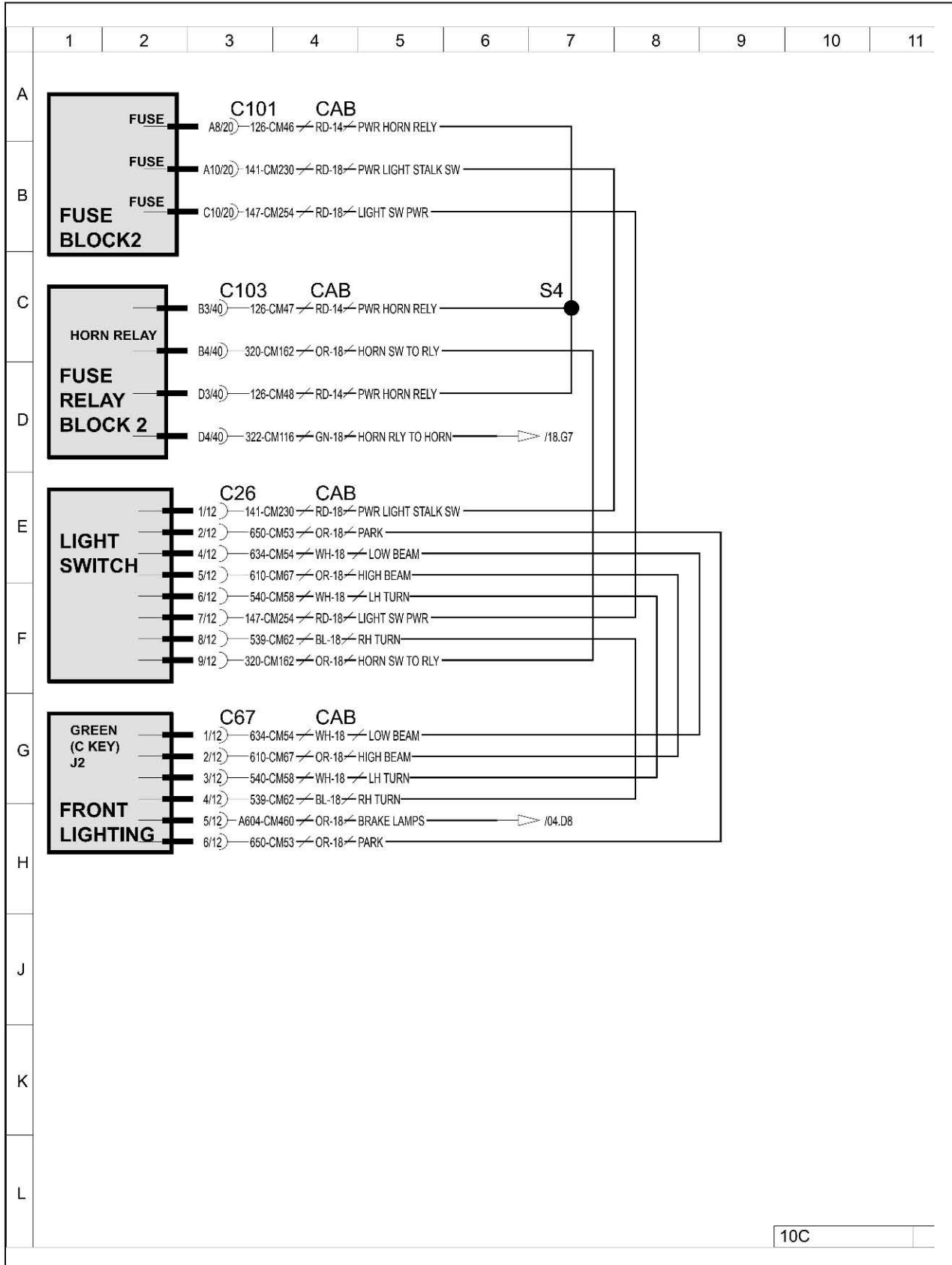

Fig. 26

18.2.23 Exhaust and NOX sensor

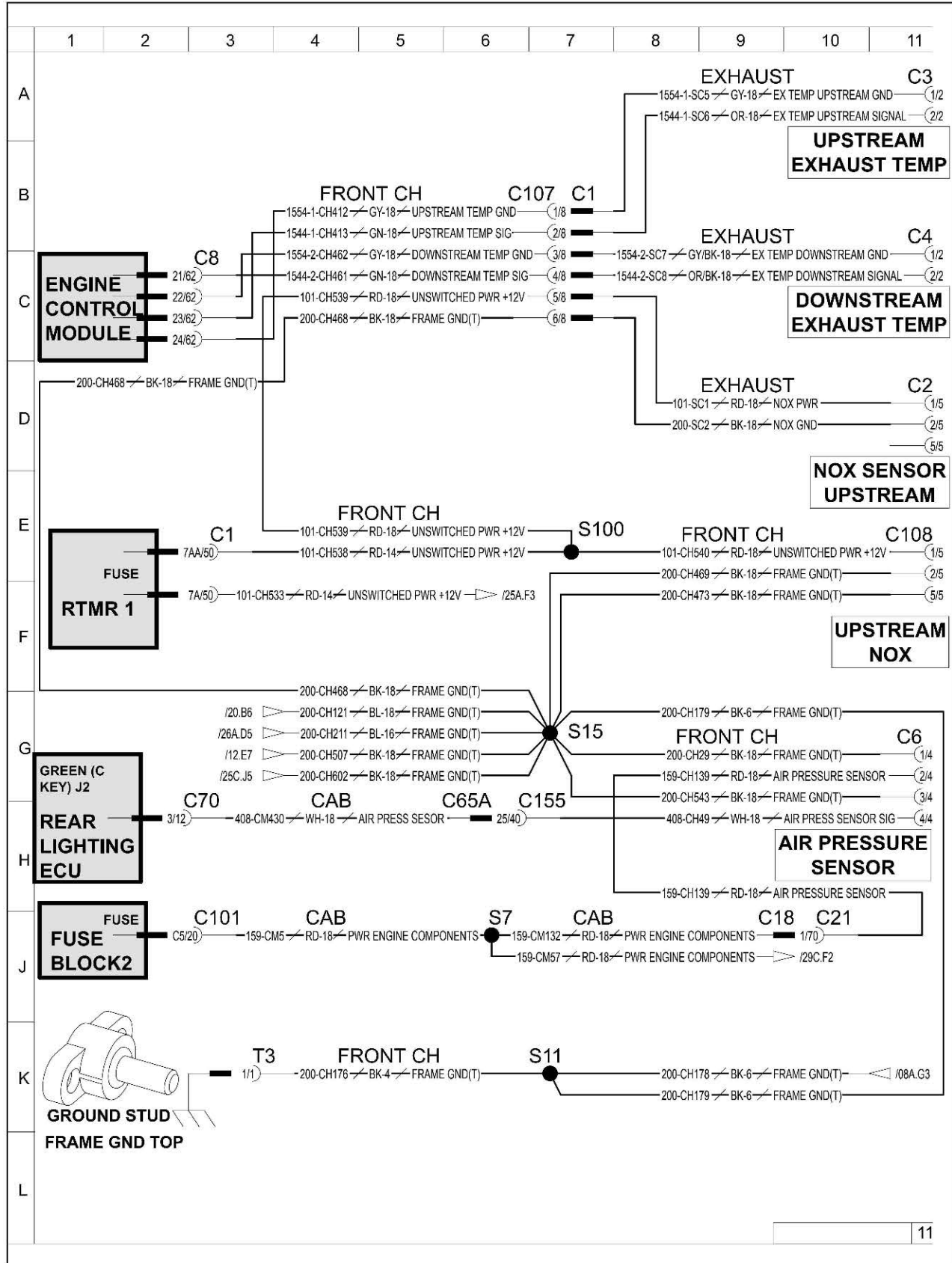

Fig. 27

18.2.24 Engine Control Module 2

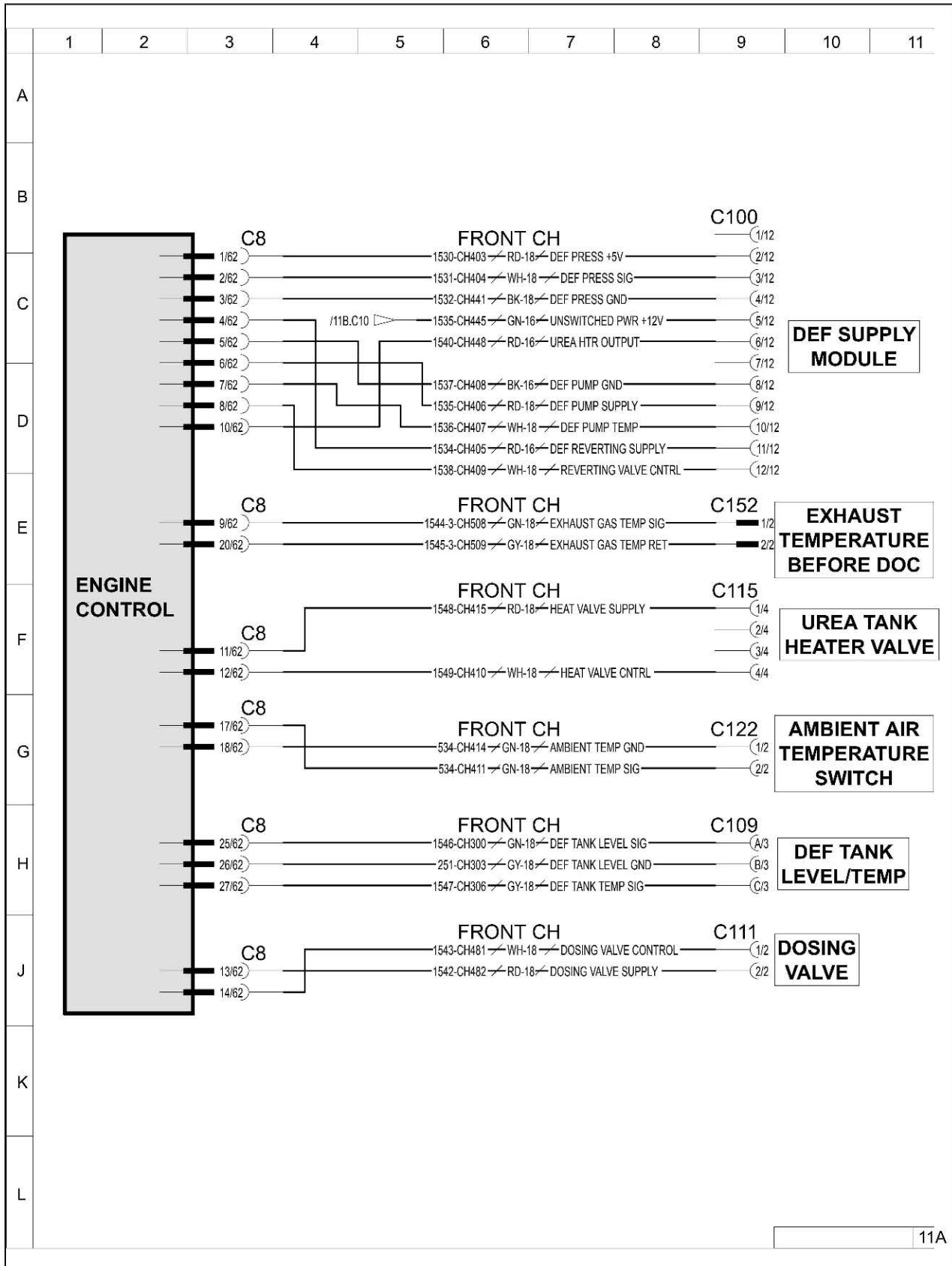

Fig. 28

18.2.25 Engine control module

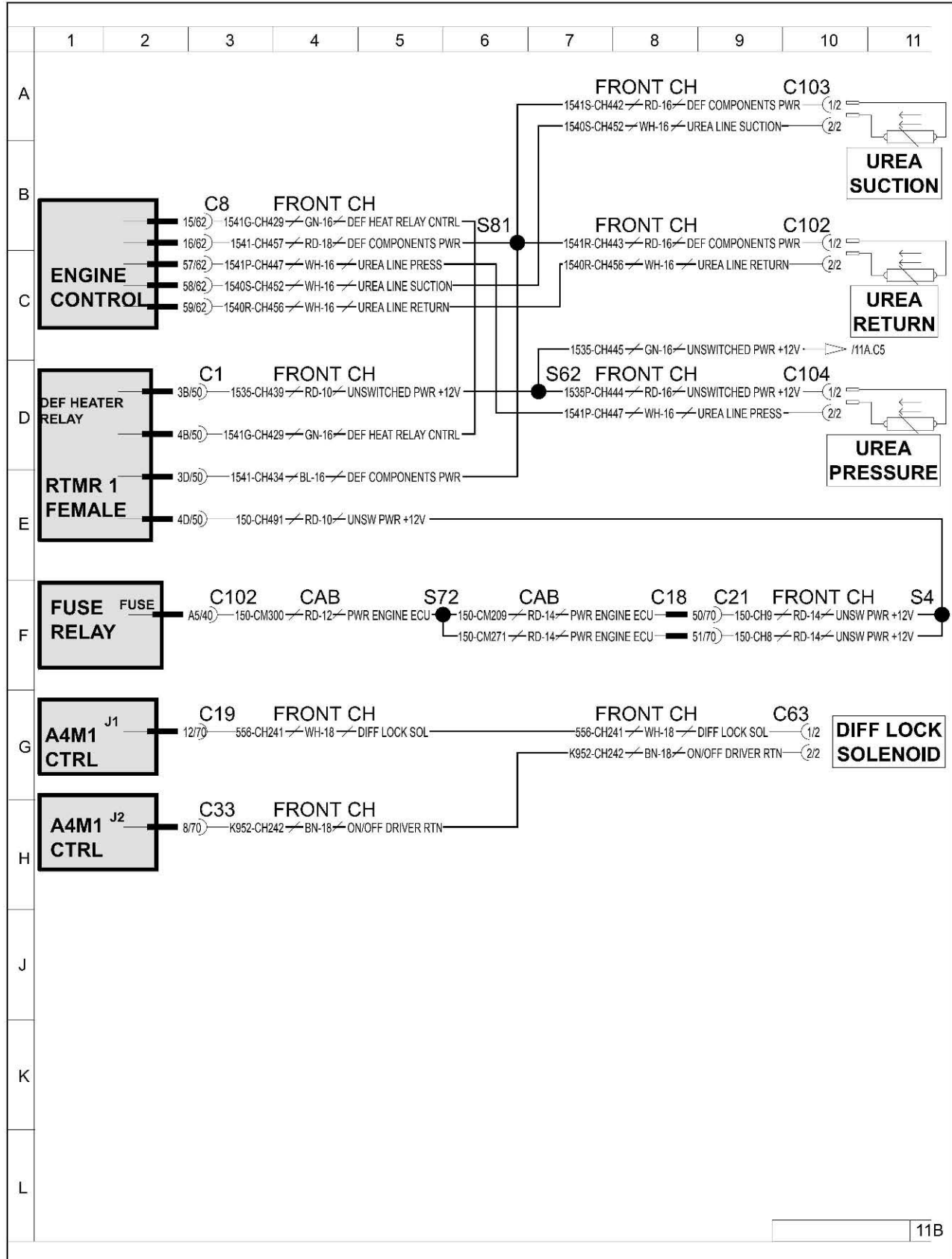

Fig. 29

18.2.26 Engine AB switch

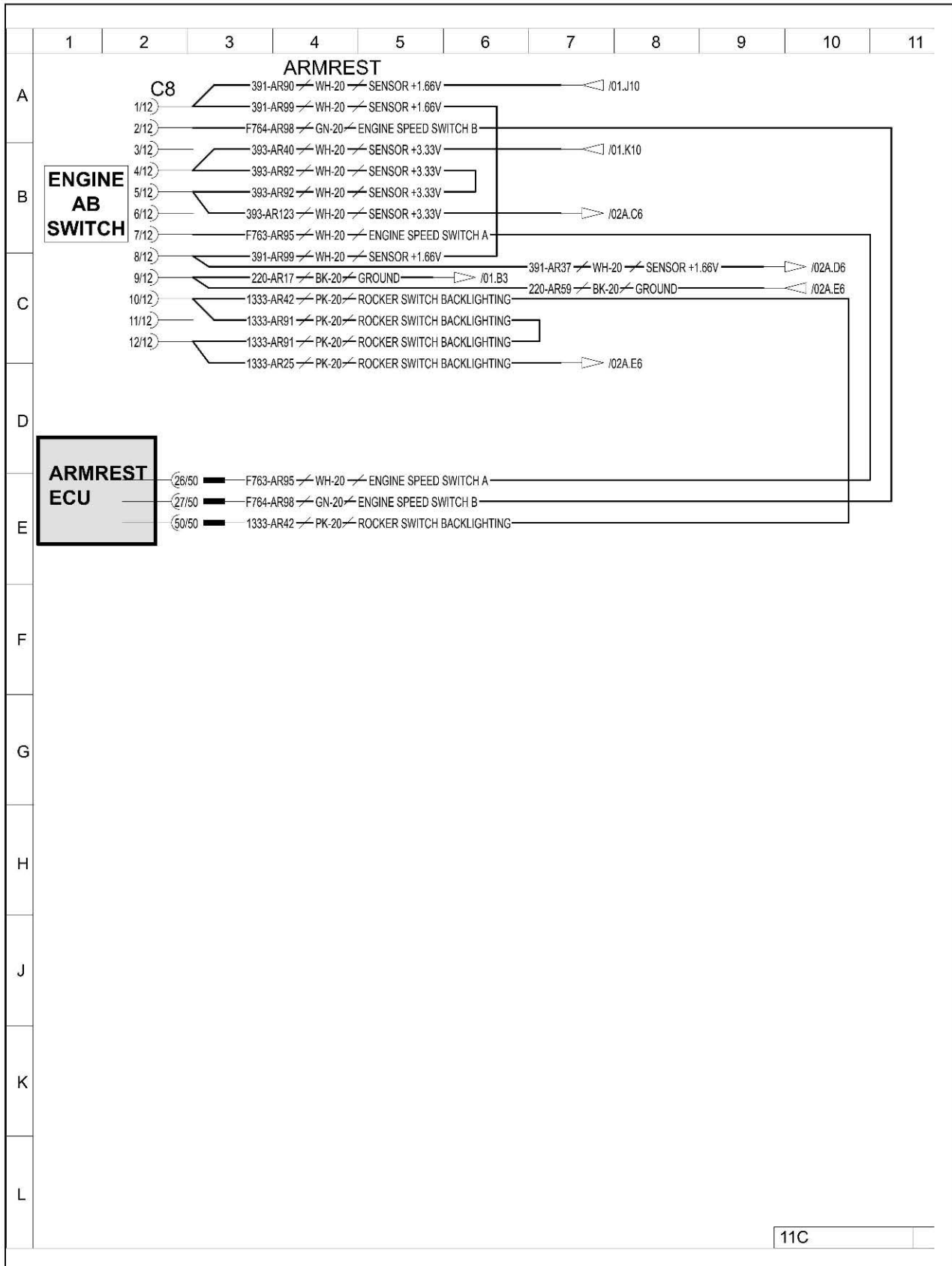

Fig. 30

18.2.27 Fan control

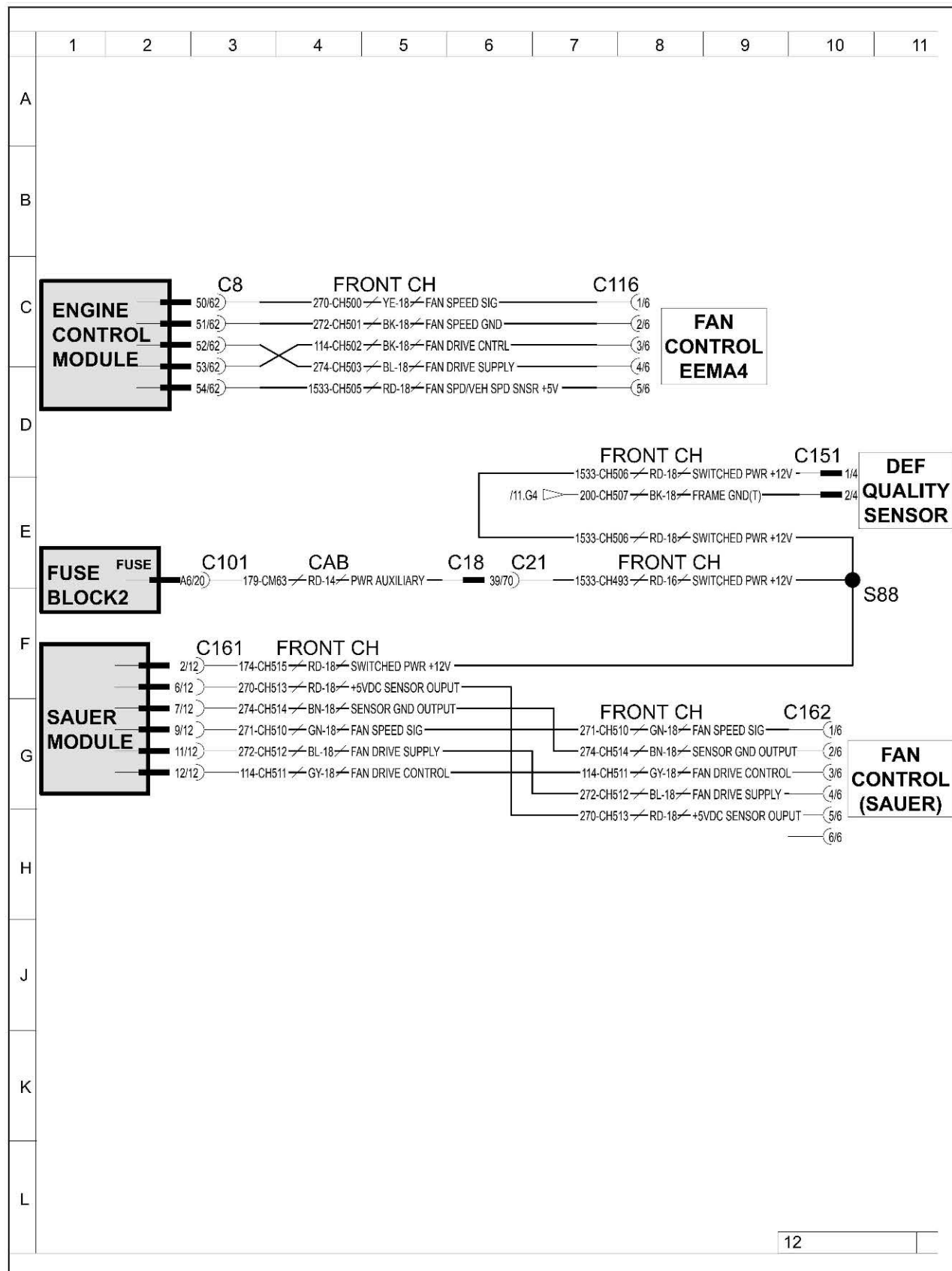

Fig. 31

18.2.28 Fuel line sensor

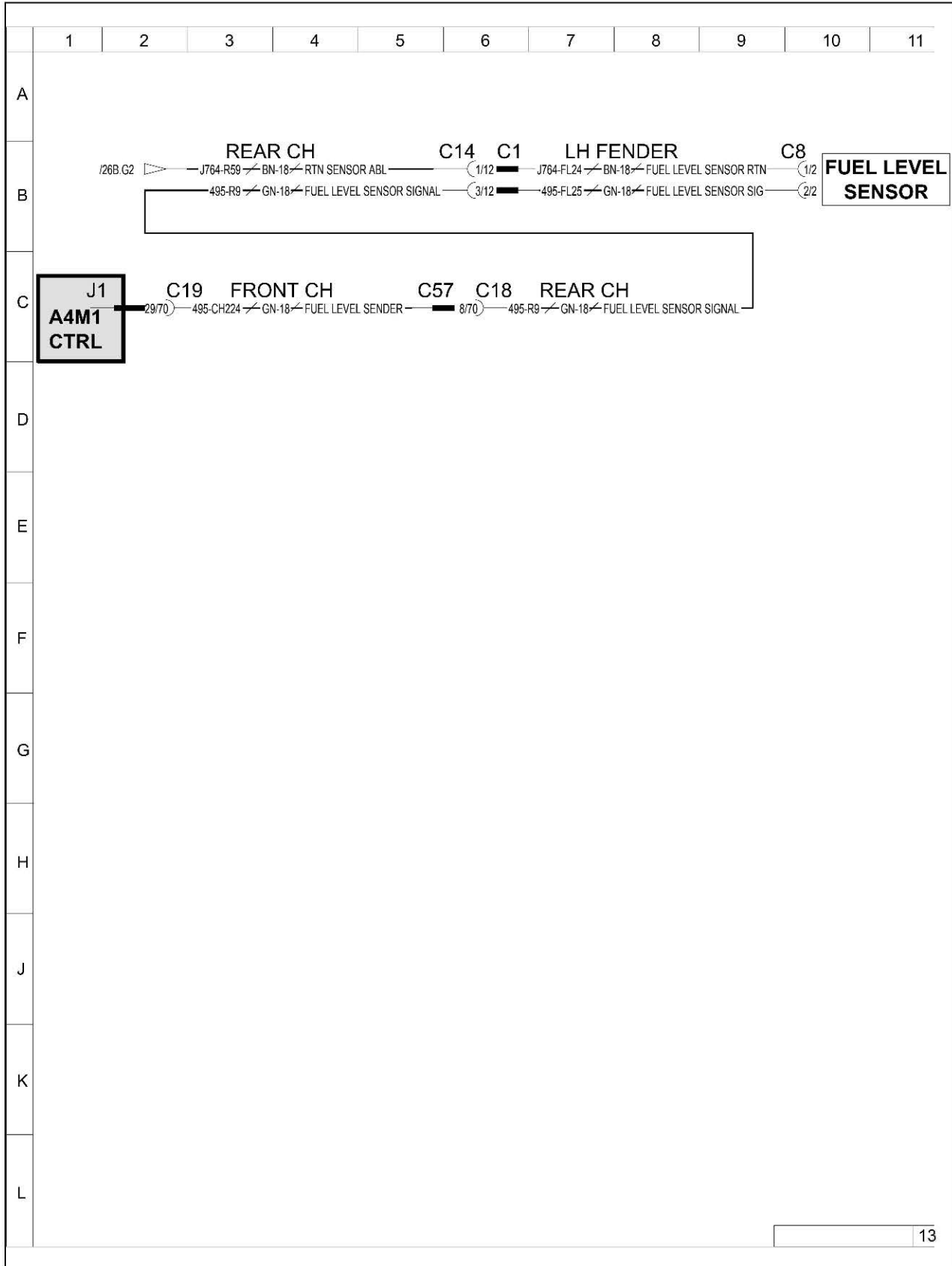

Fig. 32

18.2.29 Standard conditioner group

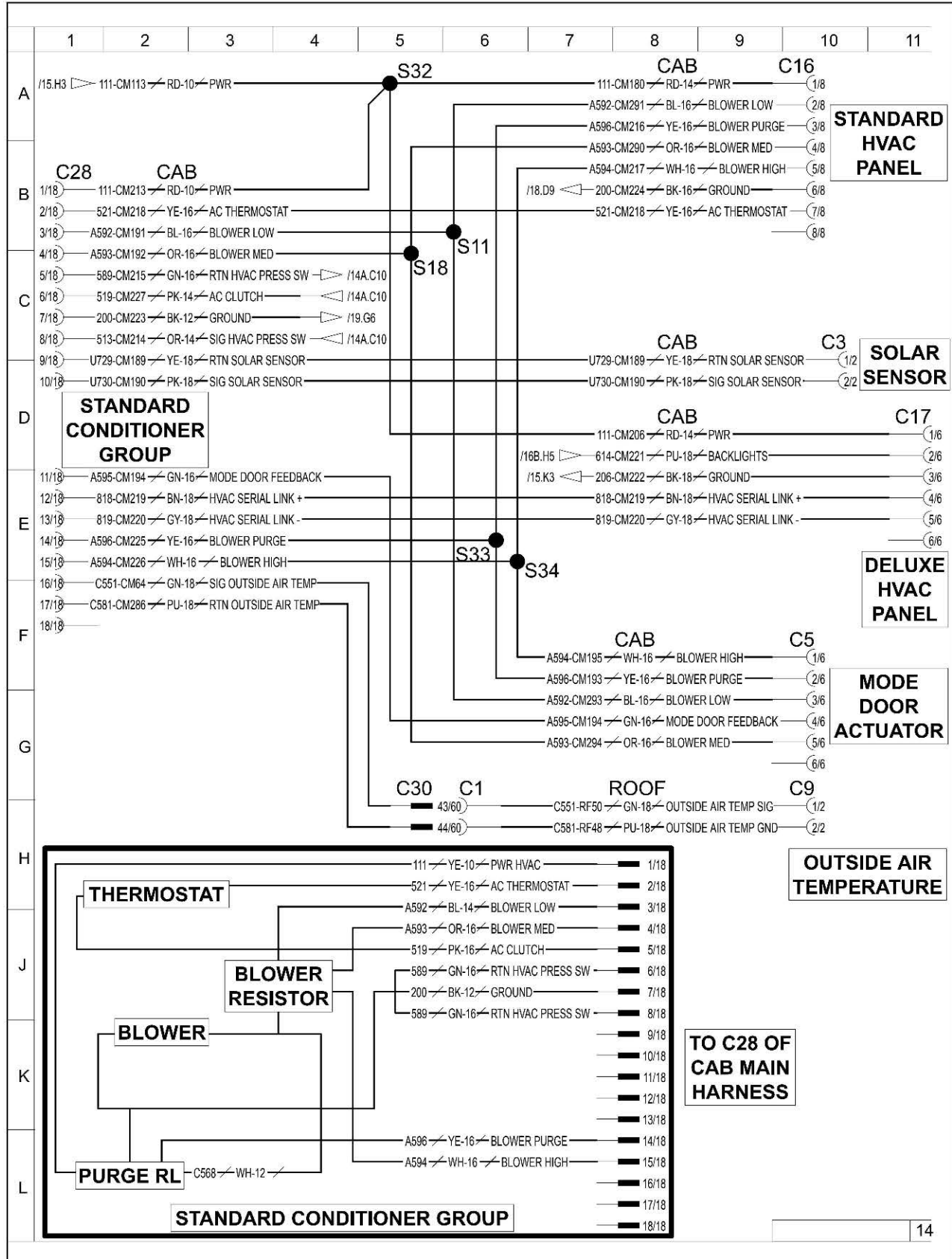

Fig. 33

18.2.30 HVAC high pressure switch

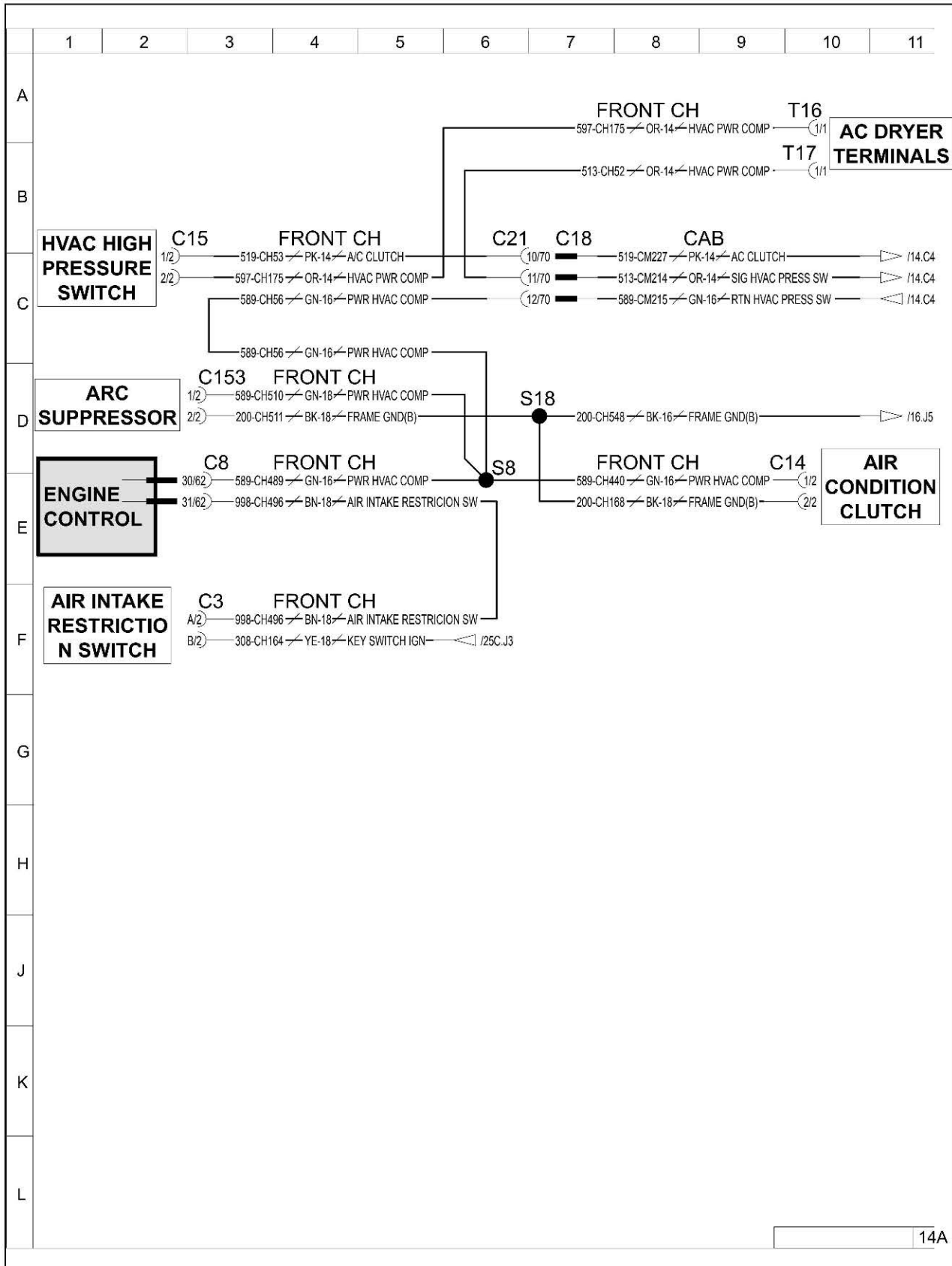

Fig. 34

18.2.31 HVAC deluxe module

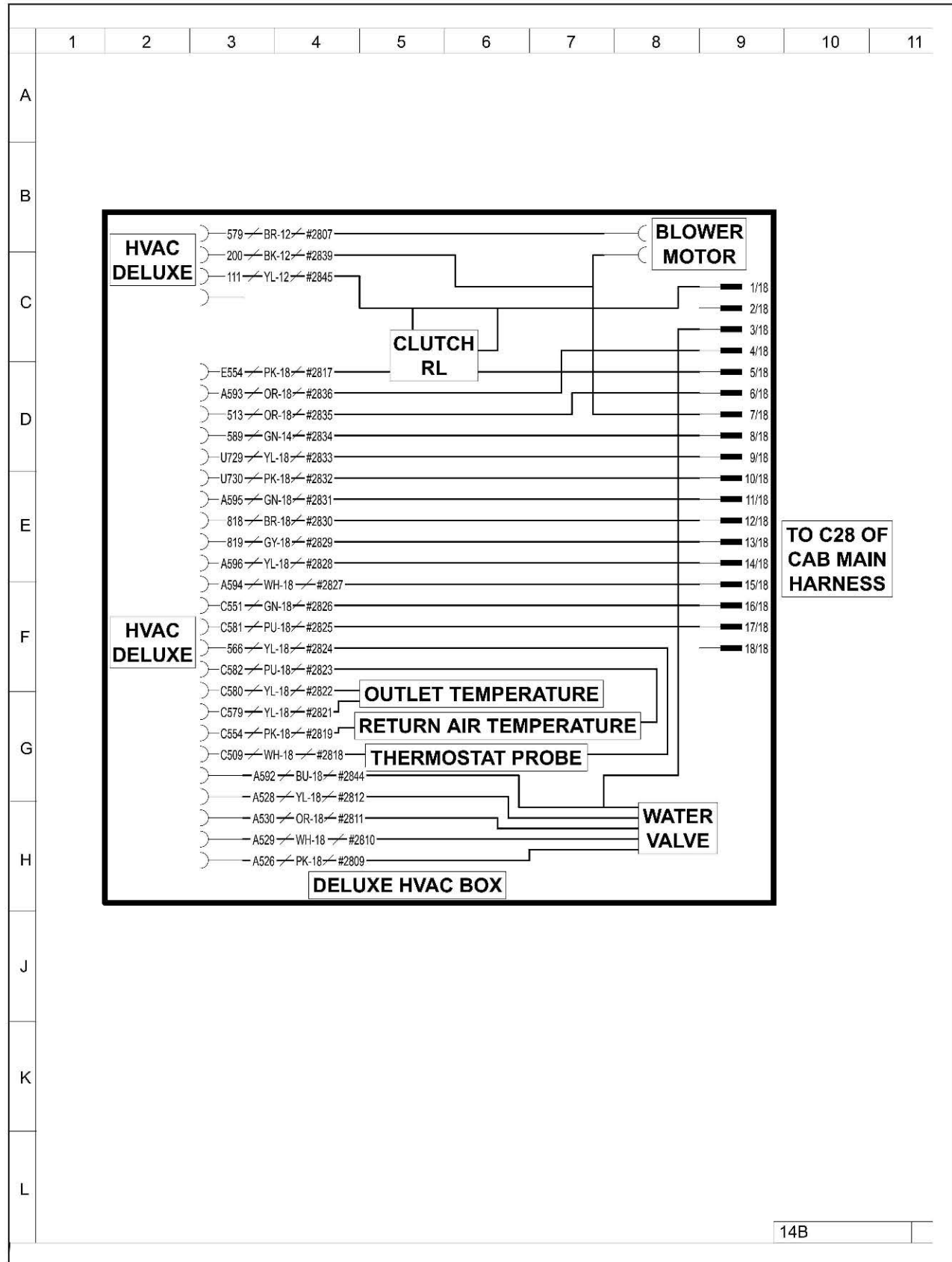

Fig. 35

18.2.32 Cab unswitched power

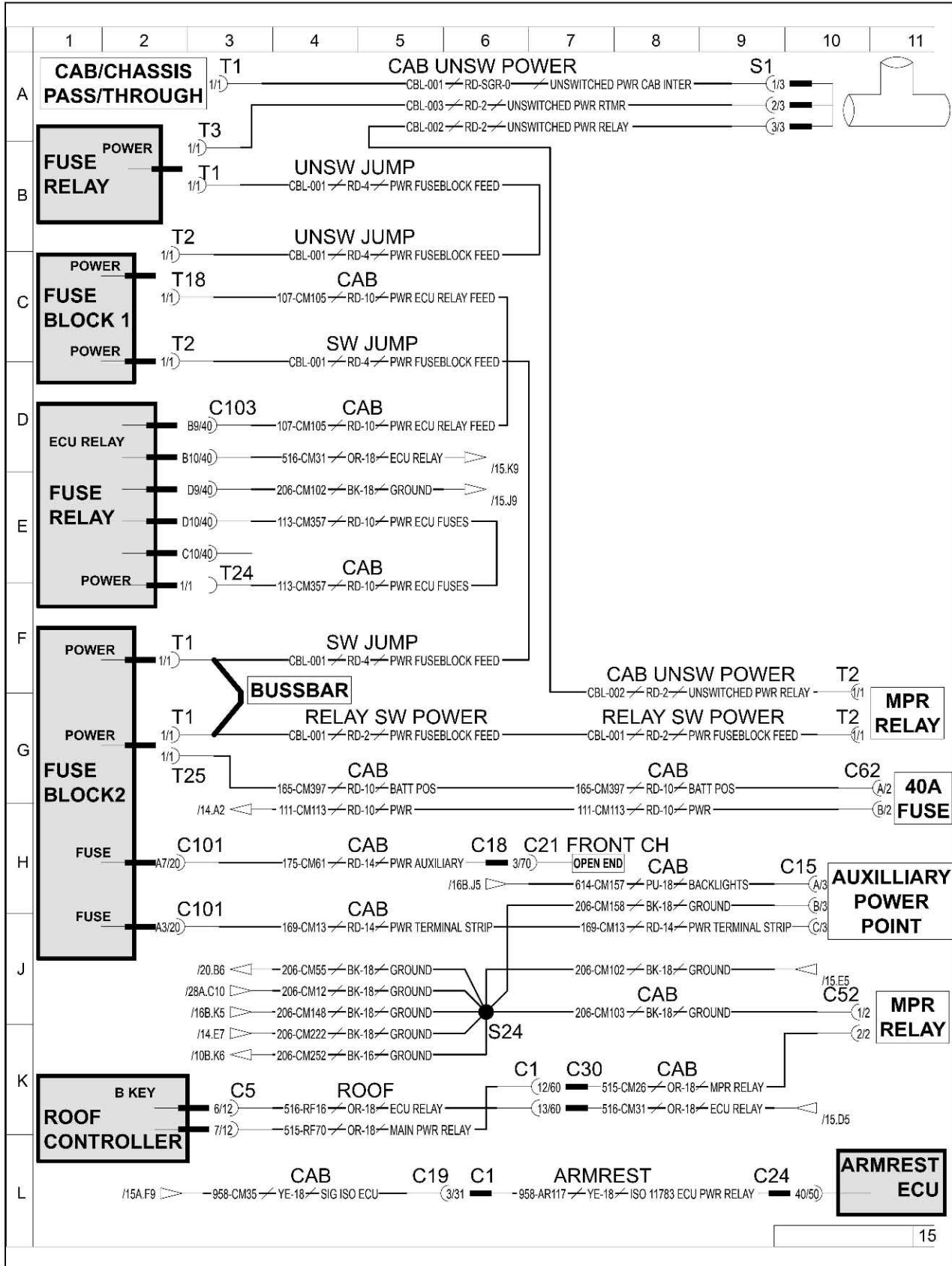

Fig. 36

18.2.33 Belt line flood lights

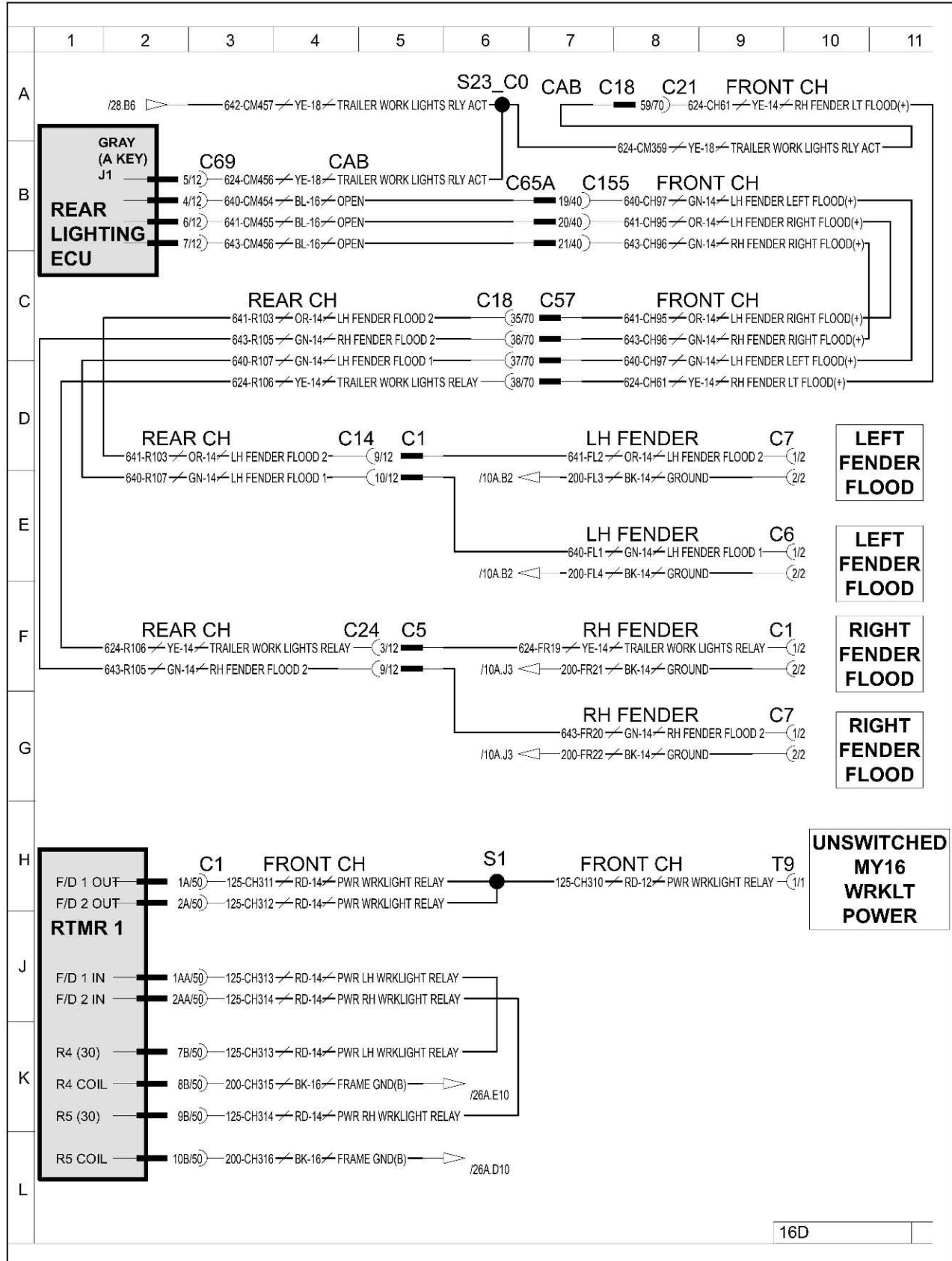

Fig. 37

18.2.34 Hood lighting

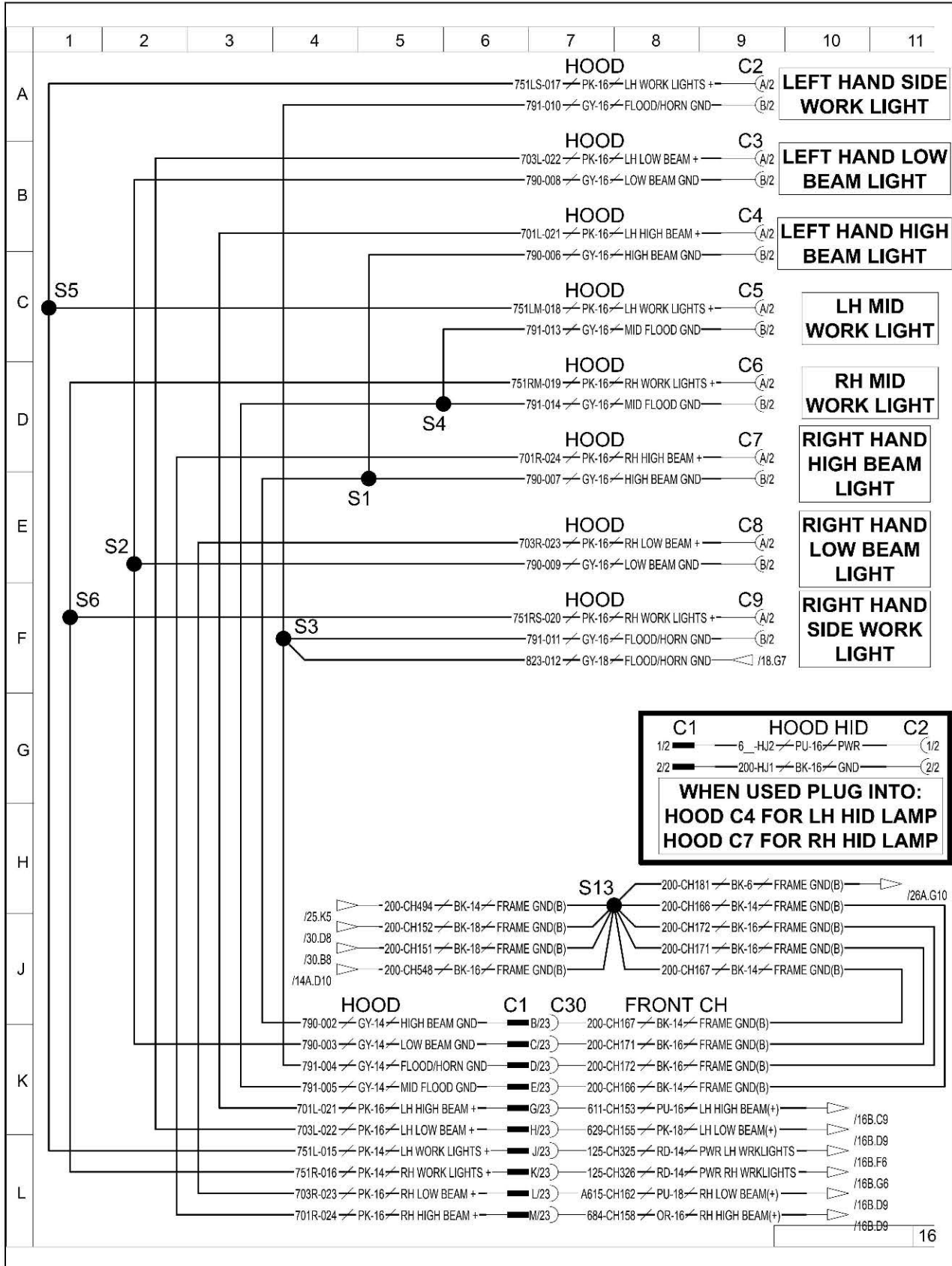

Fig. 38

18.2.35 Flood and hazard switch

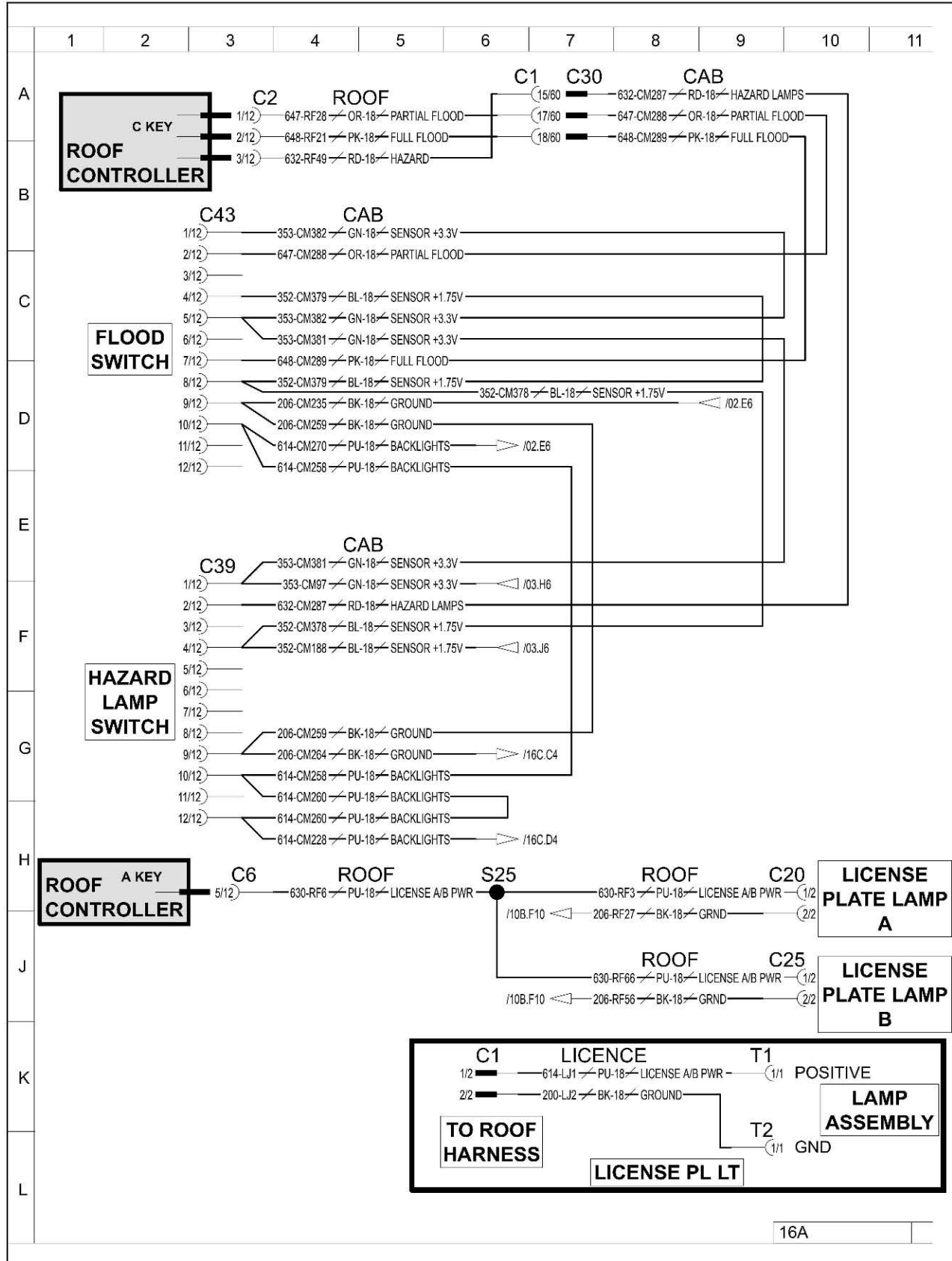

Fig. 39

18.2.36 Hood harness and courtesy lamp

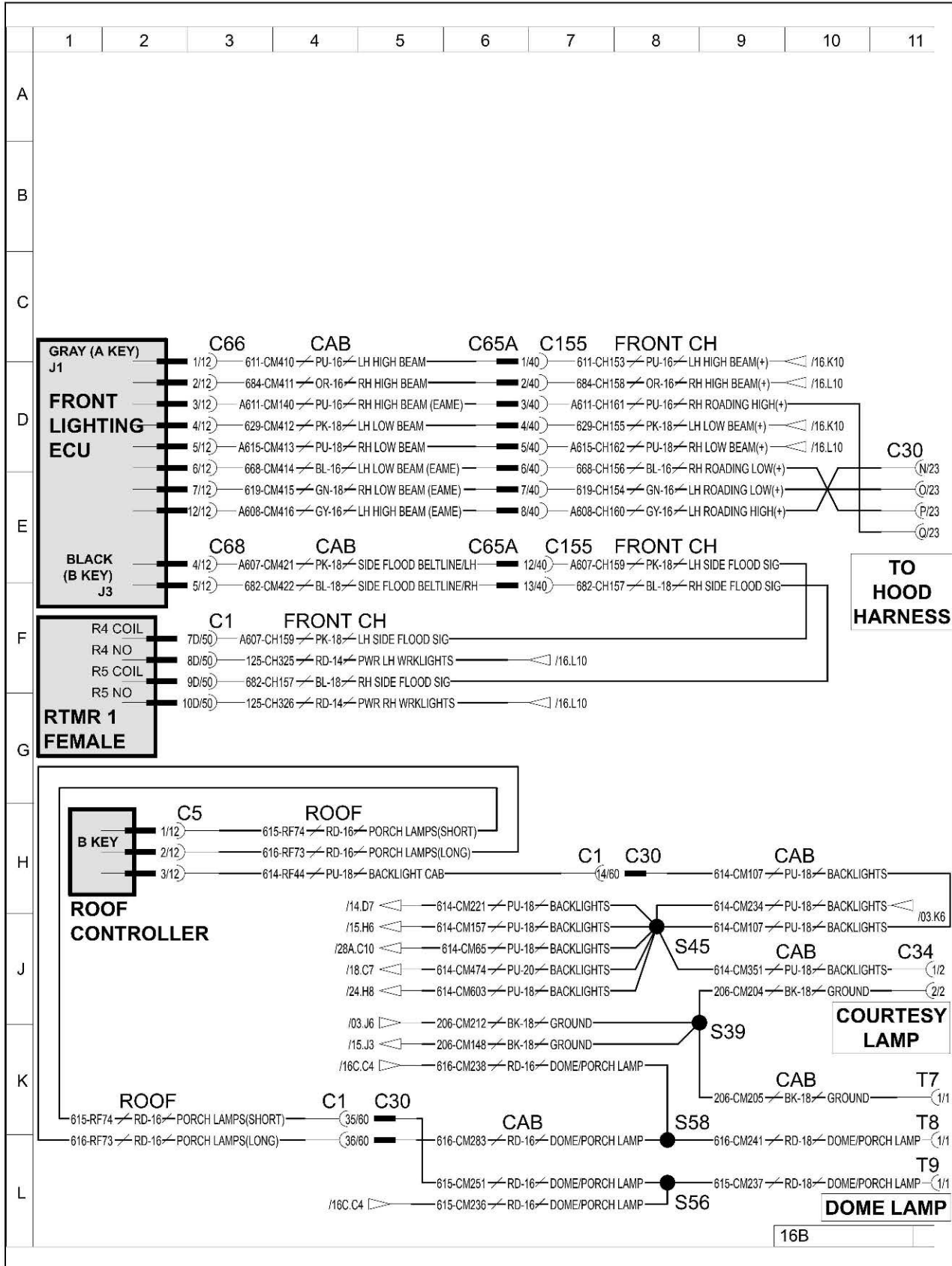

Fig. 40

18.2.37 Porch and flood lights

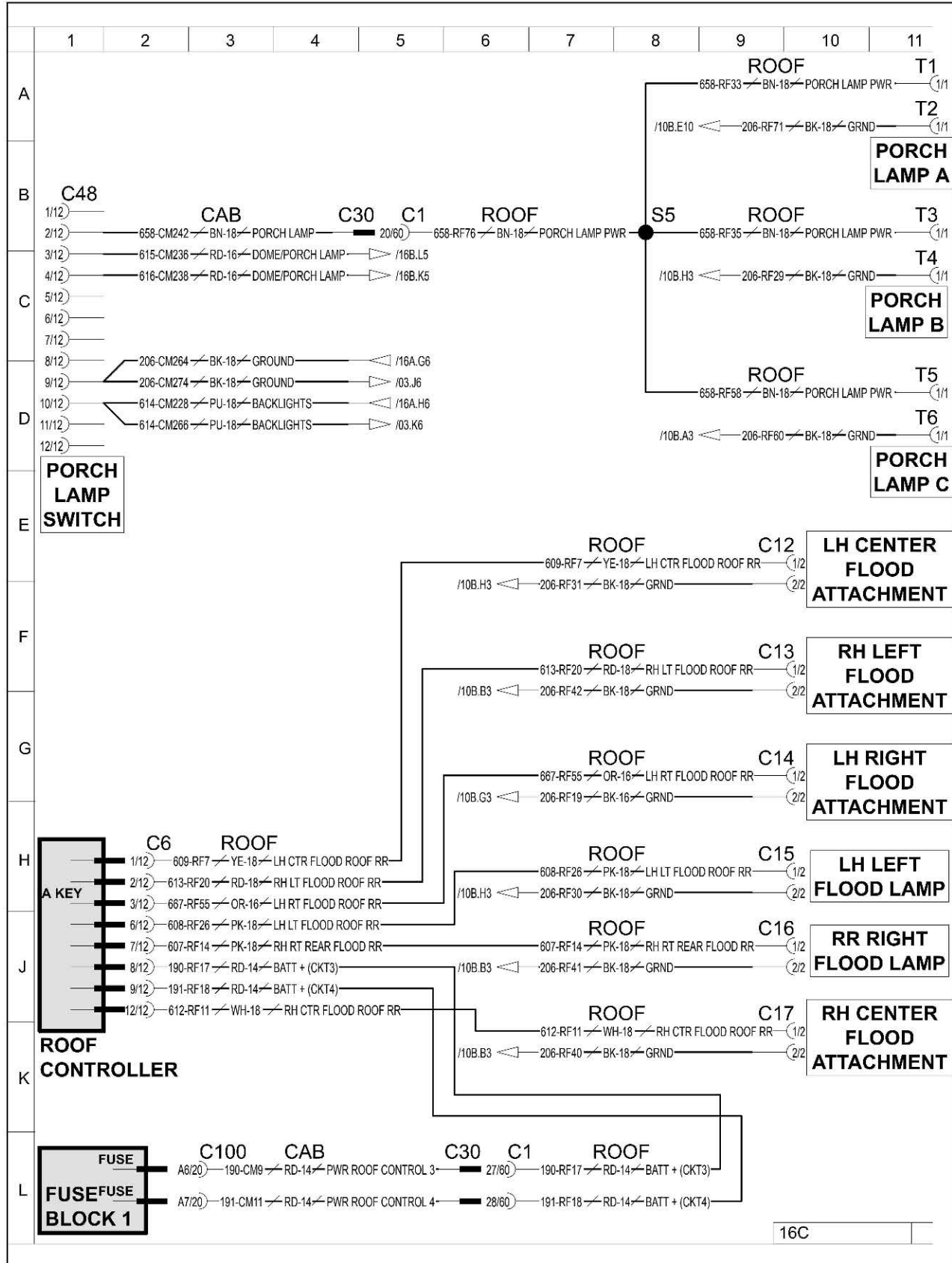

Fig. 41

18.2.38 Rear working lights

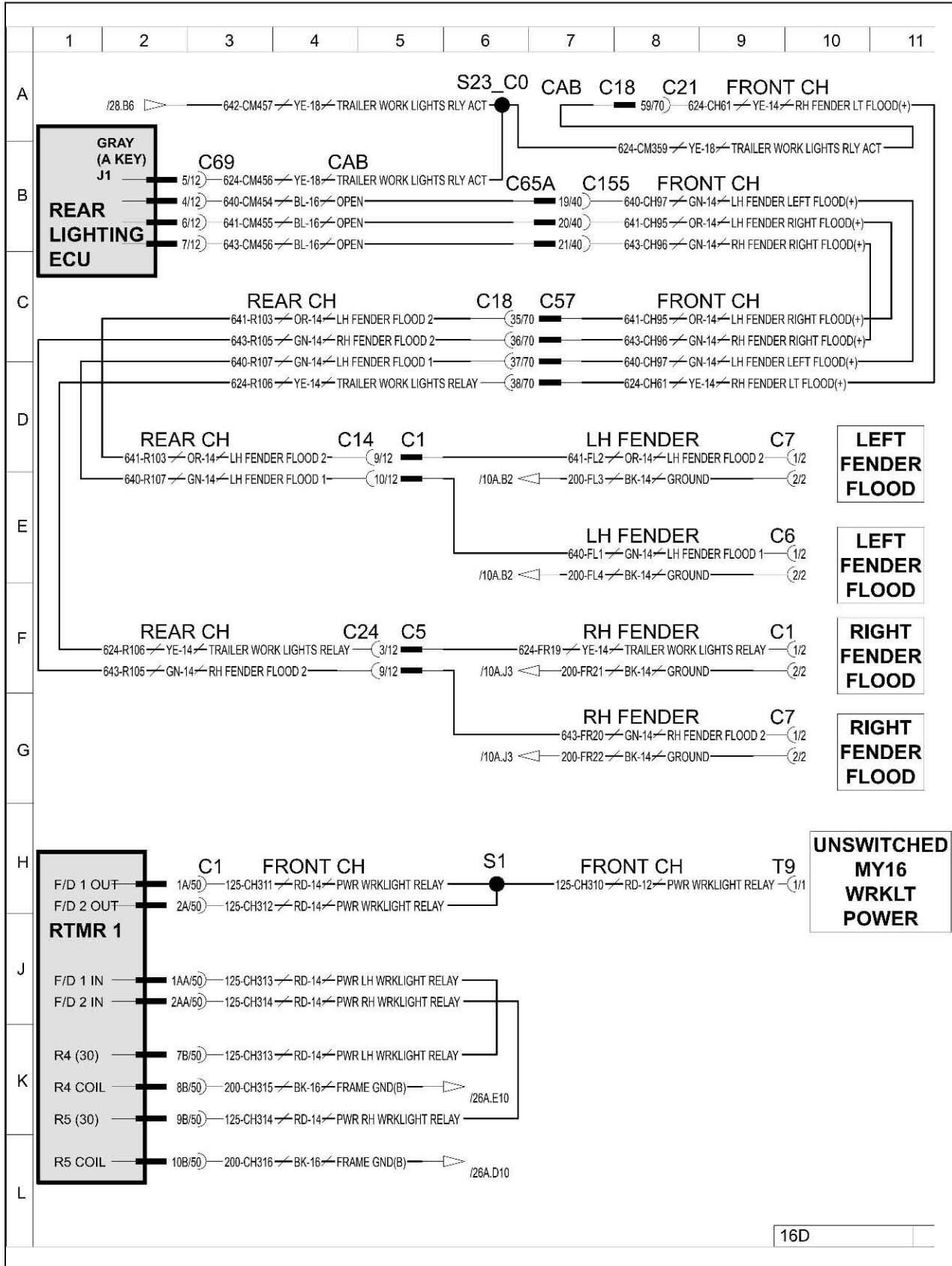

Fig. 42

18.2.39 Heated mirrors

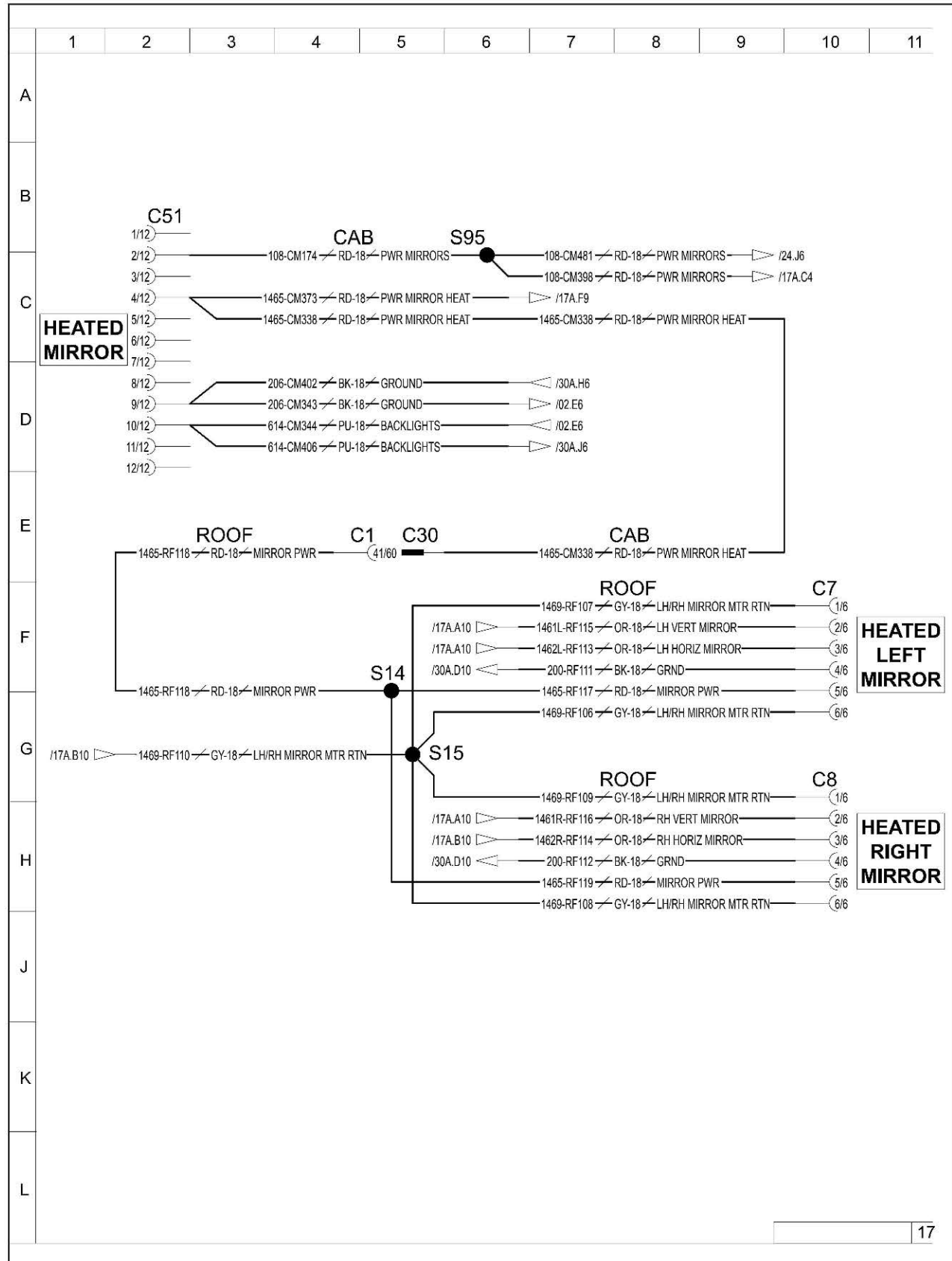

Fig. 43

18.2.40 Mirror switch

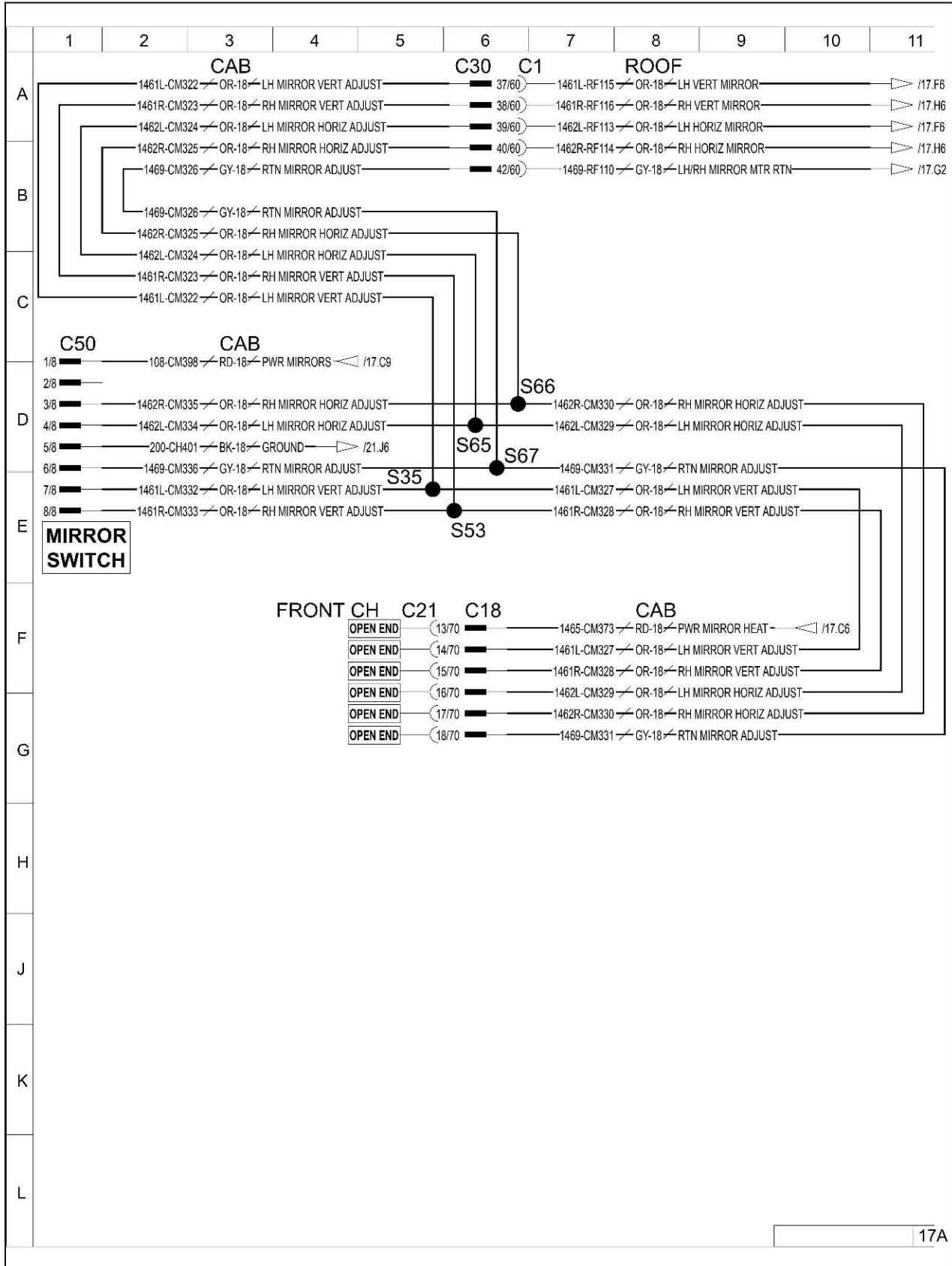

Fig. 44

18.2.41 USB charging port

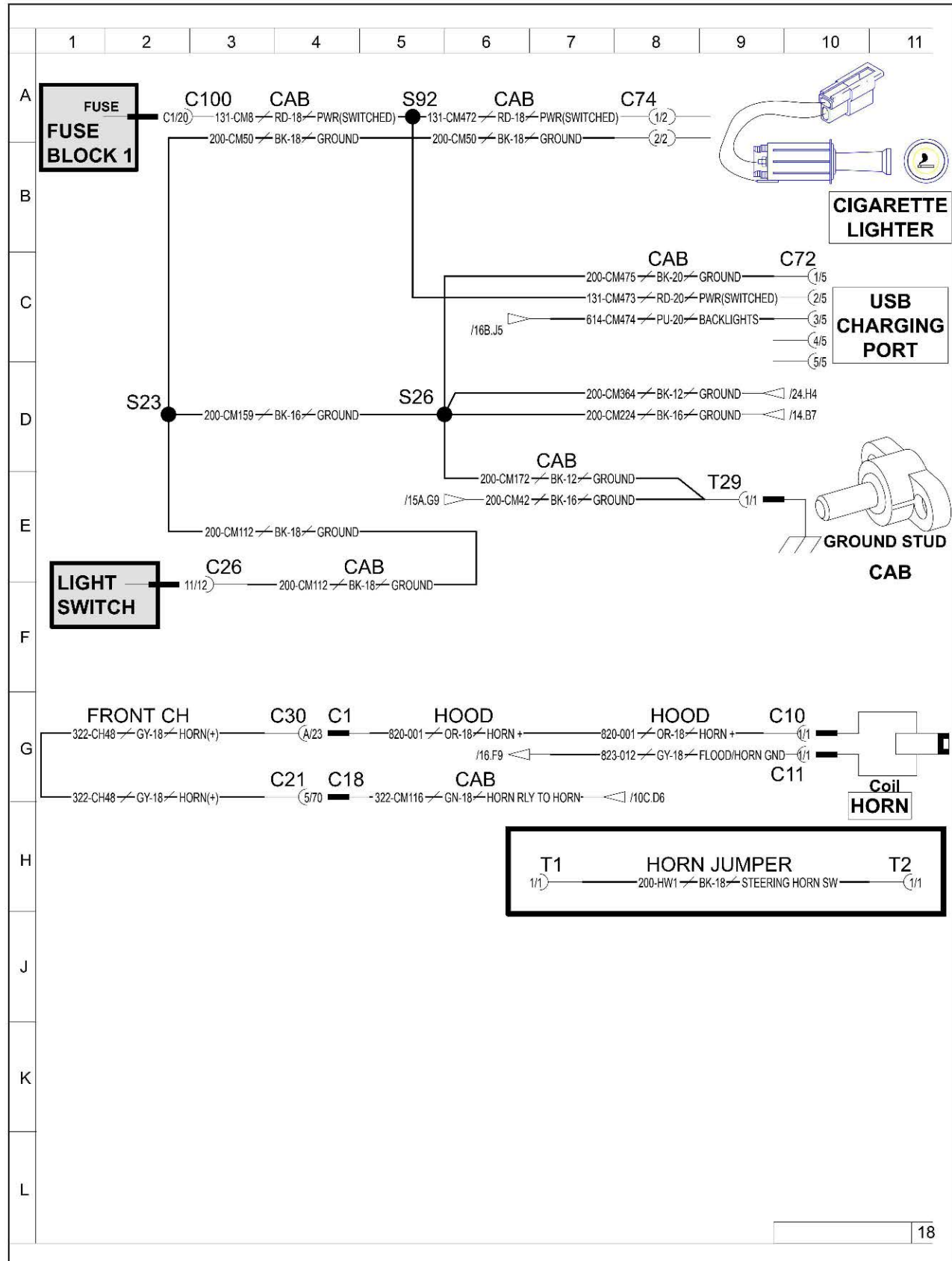

Fig. 45

18.2.42 Power strip

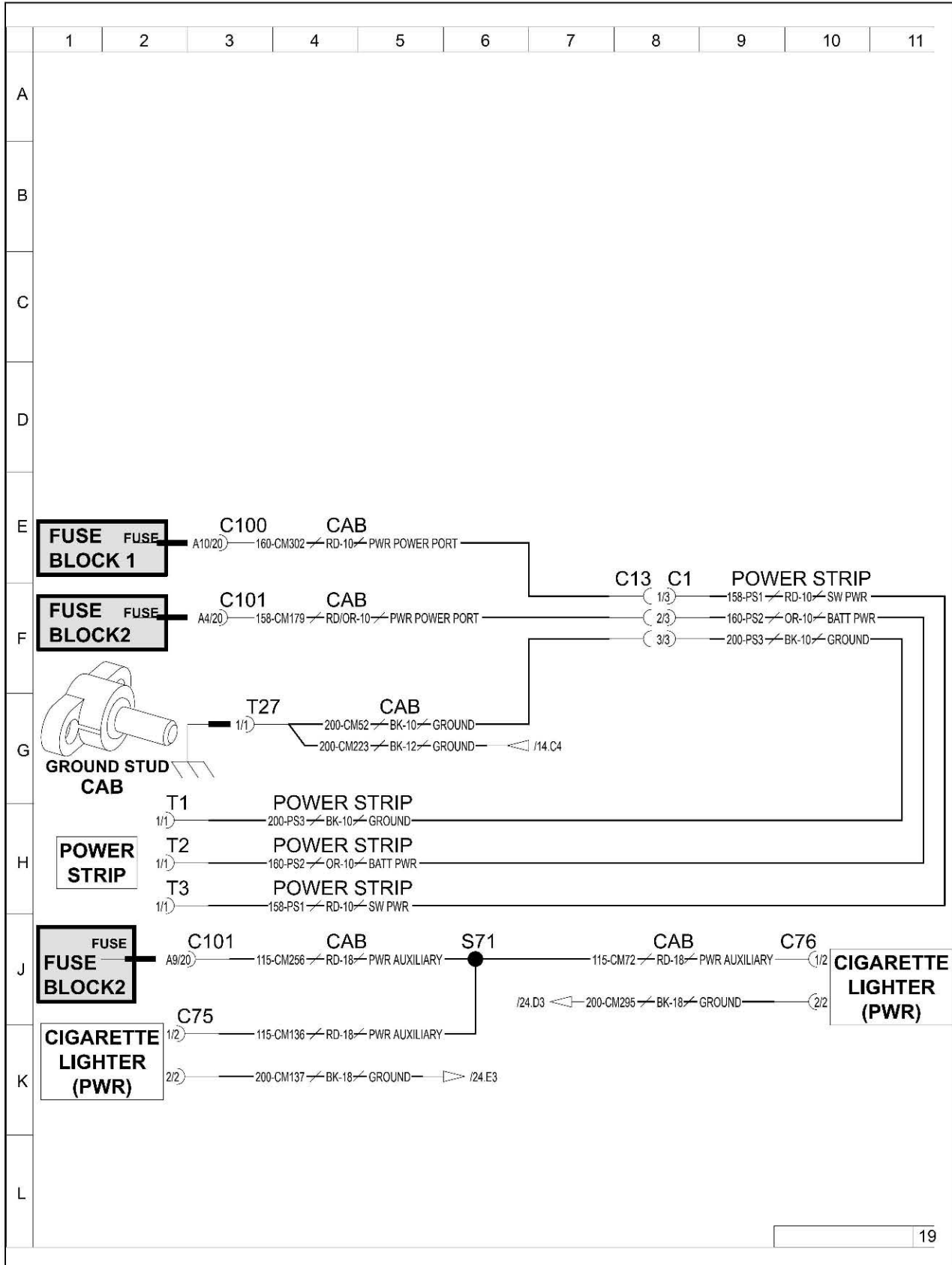

Fig. 46

18.2.43 Radar

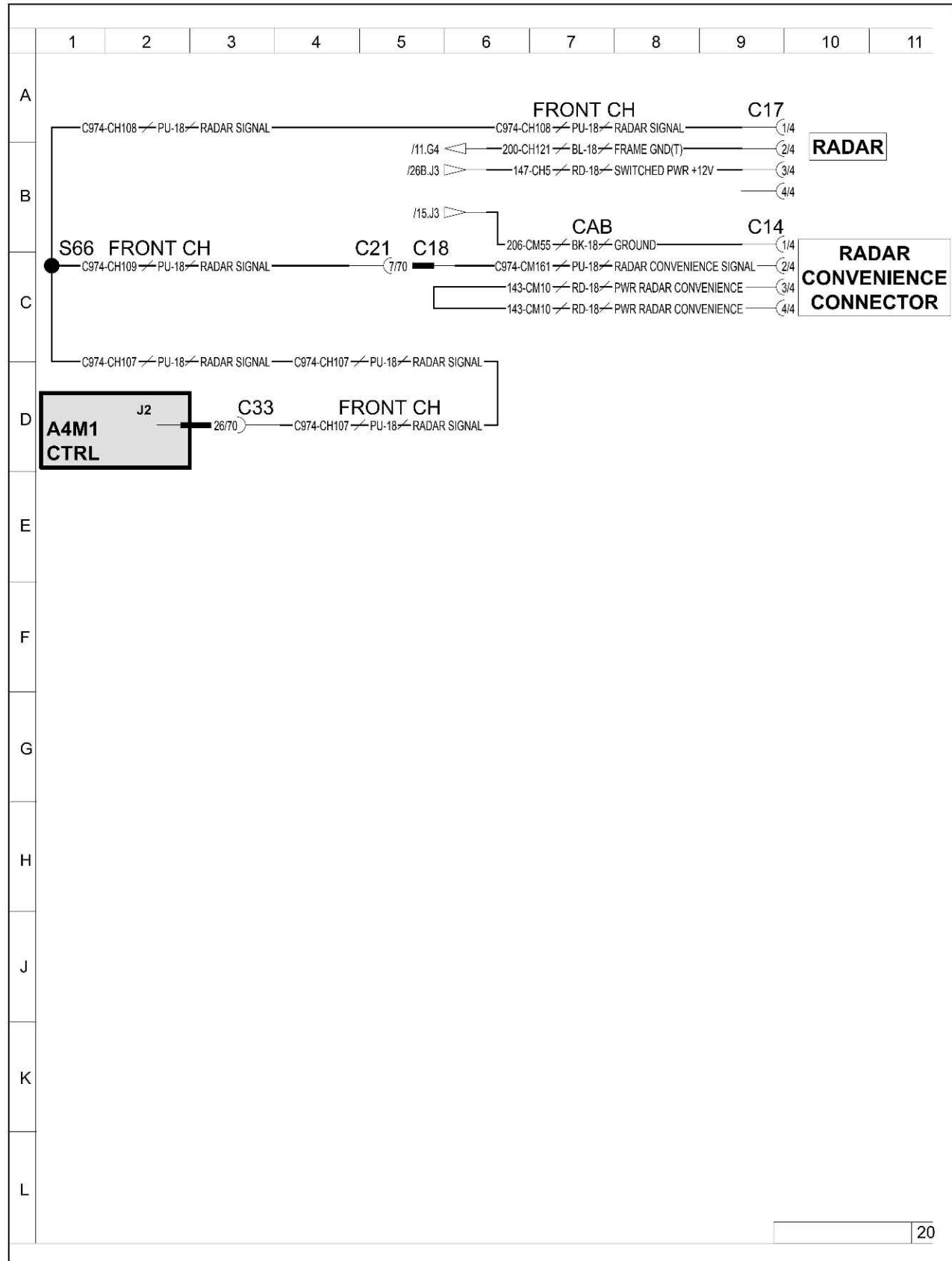

Fig. 47

18.2.44 Radio and speakers

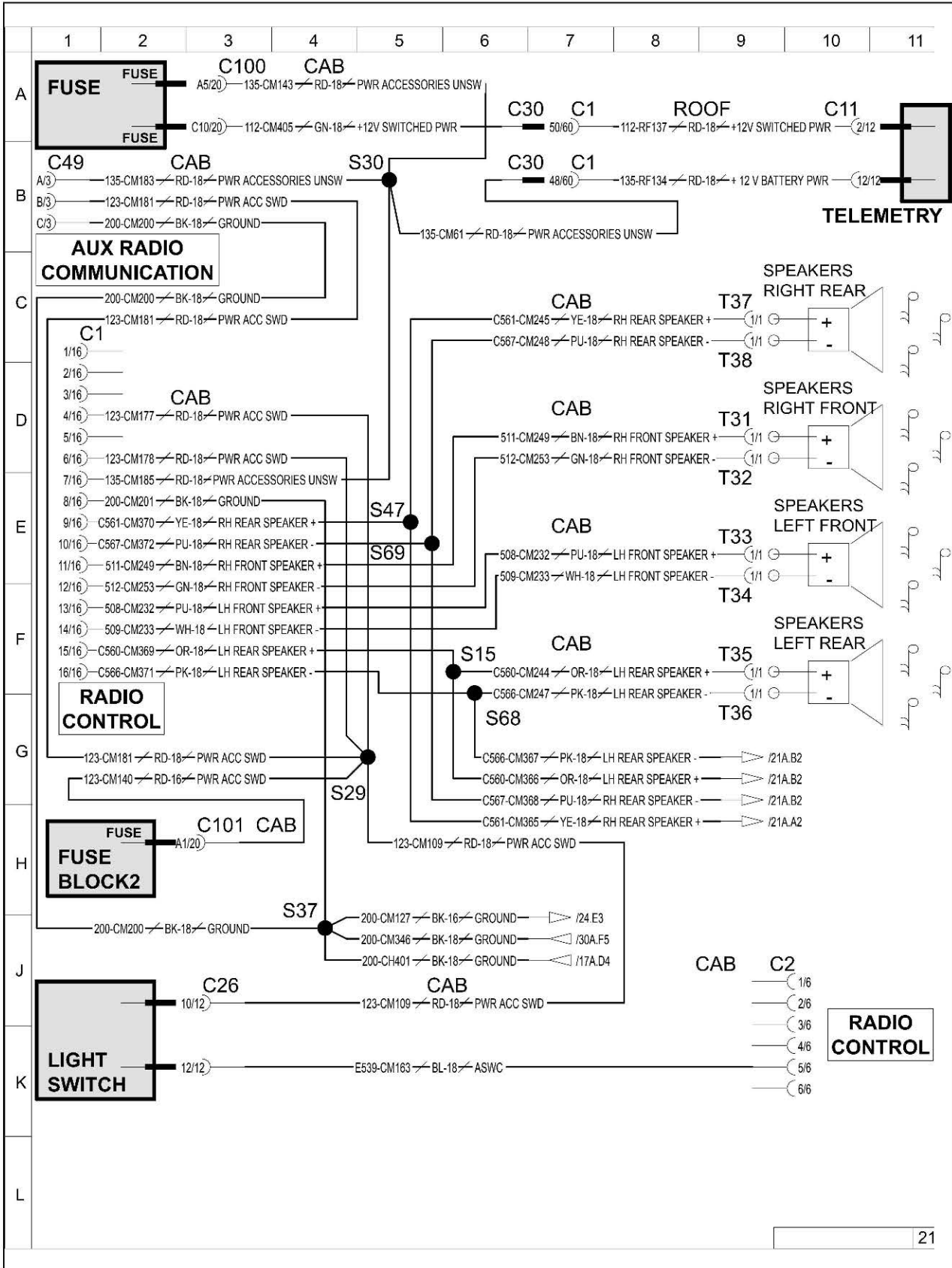

Fig. 48

18.2.45 Woofer

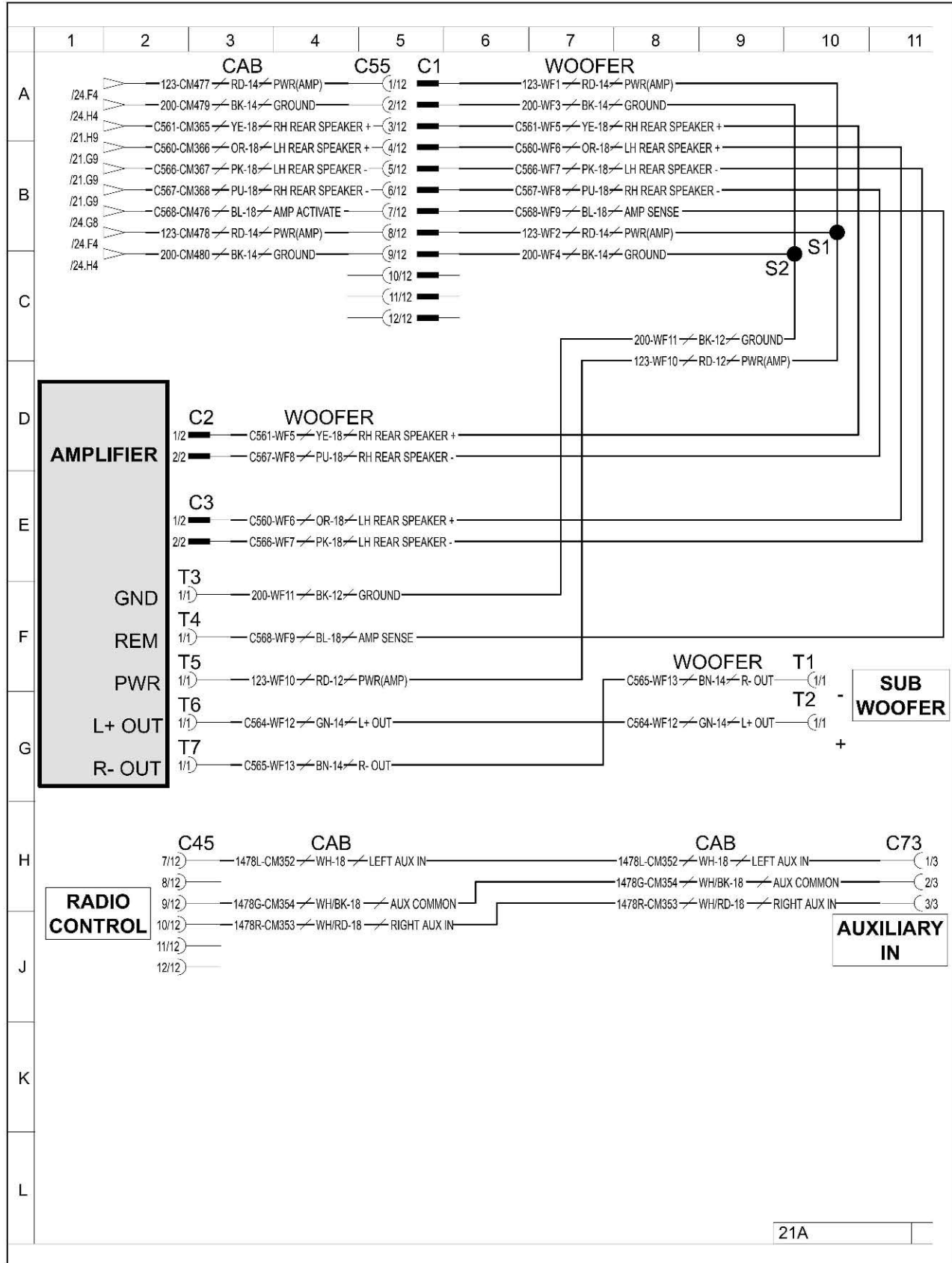

Fig. 49

18.2.46 Remote steer

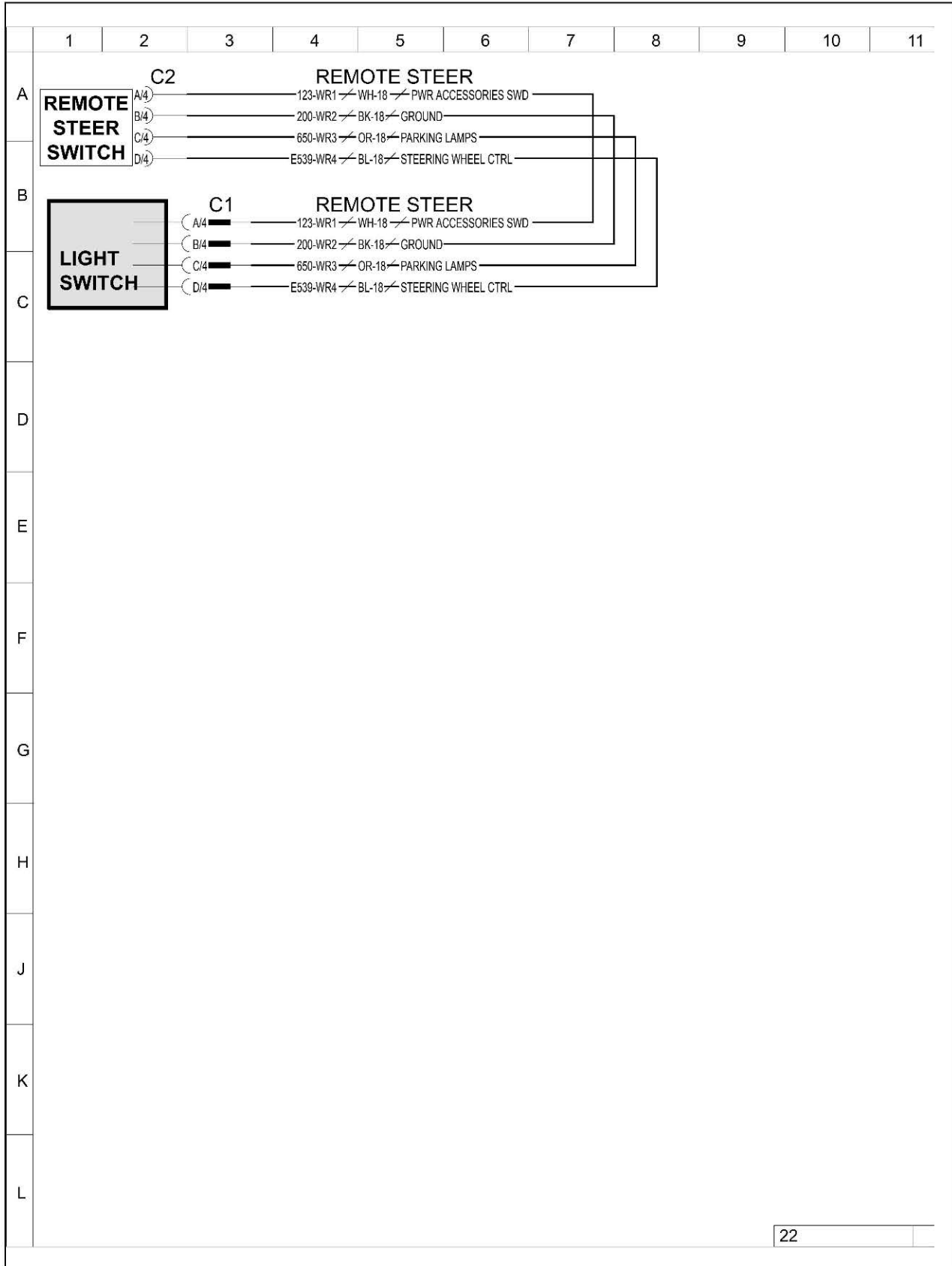

Fig. 50

18.2.47 Rear reverse lamps

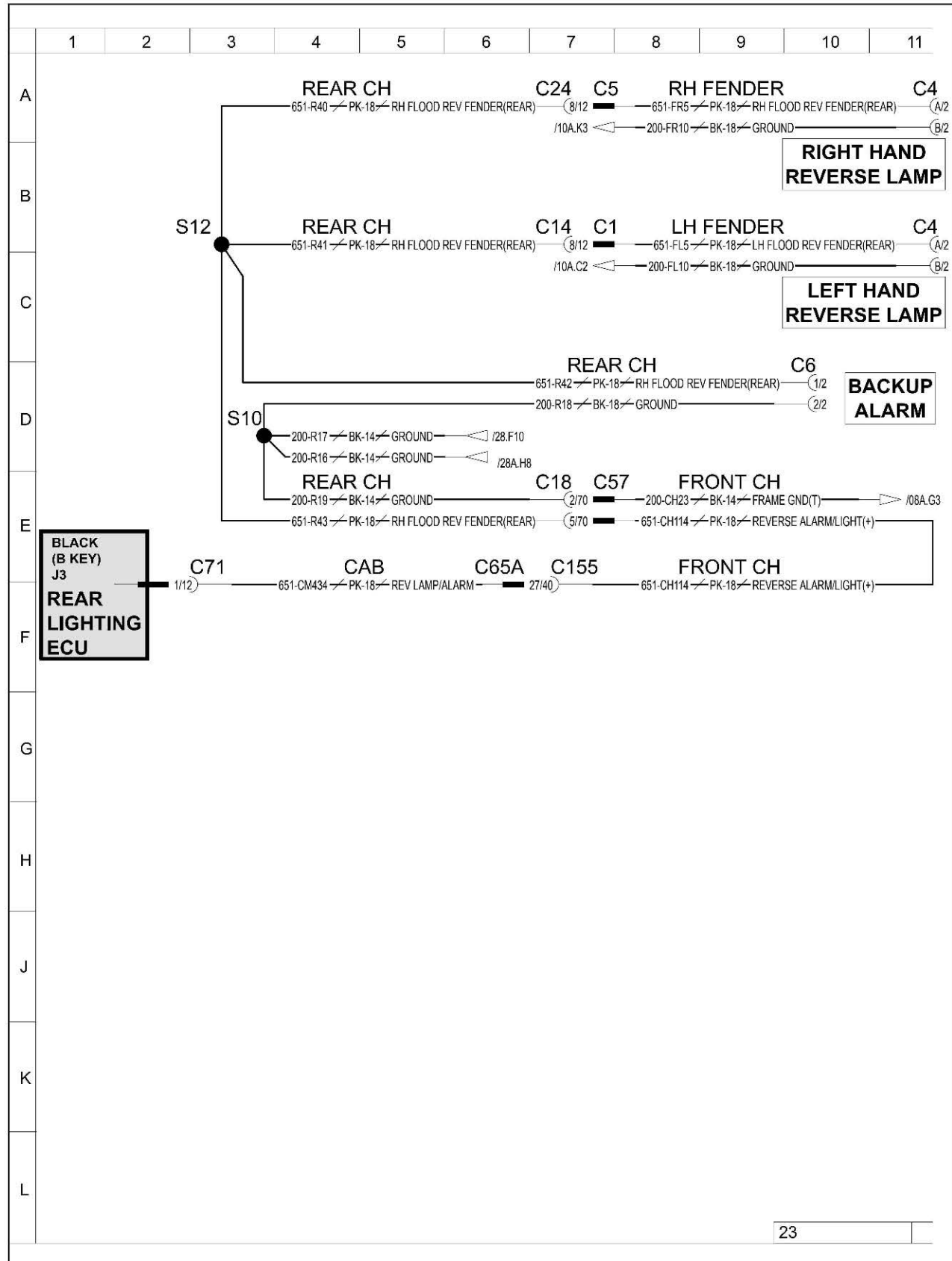

Fig. 51

18.2.48 Seat group

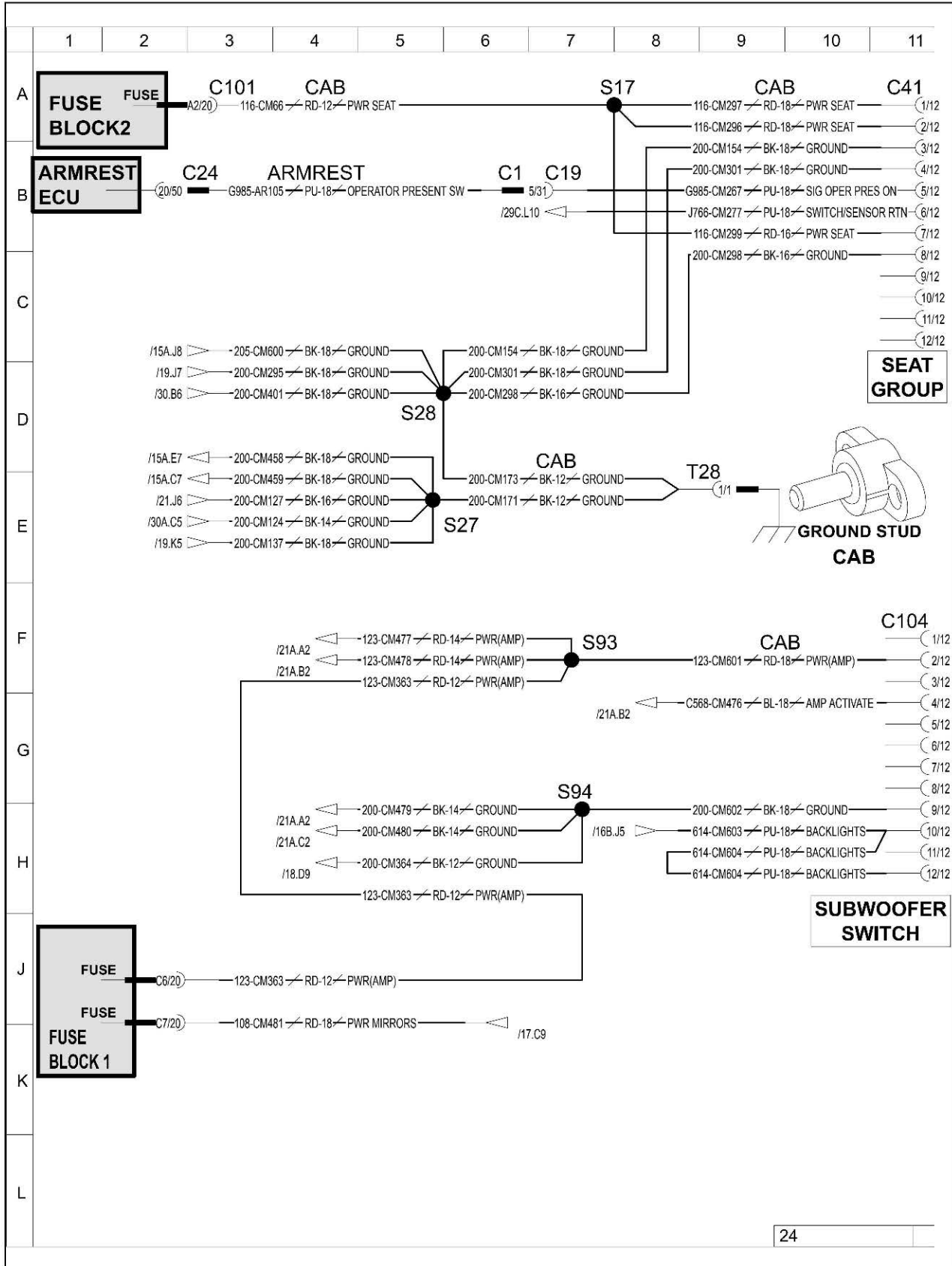

Fig. 52

18.2.50 ECM power

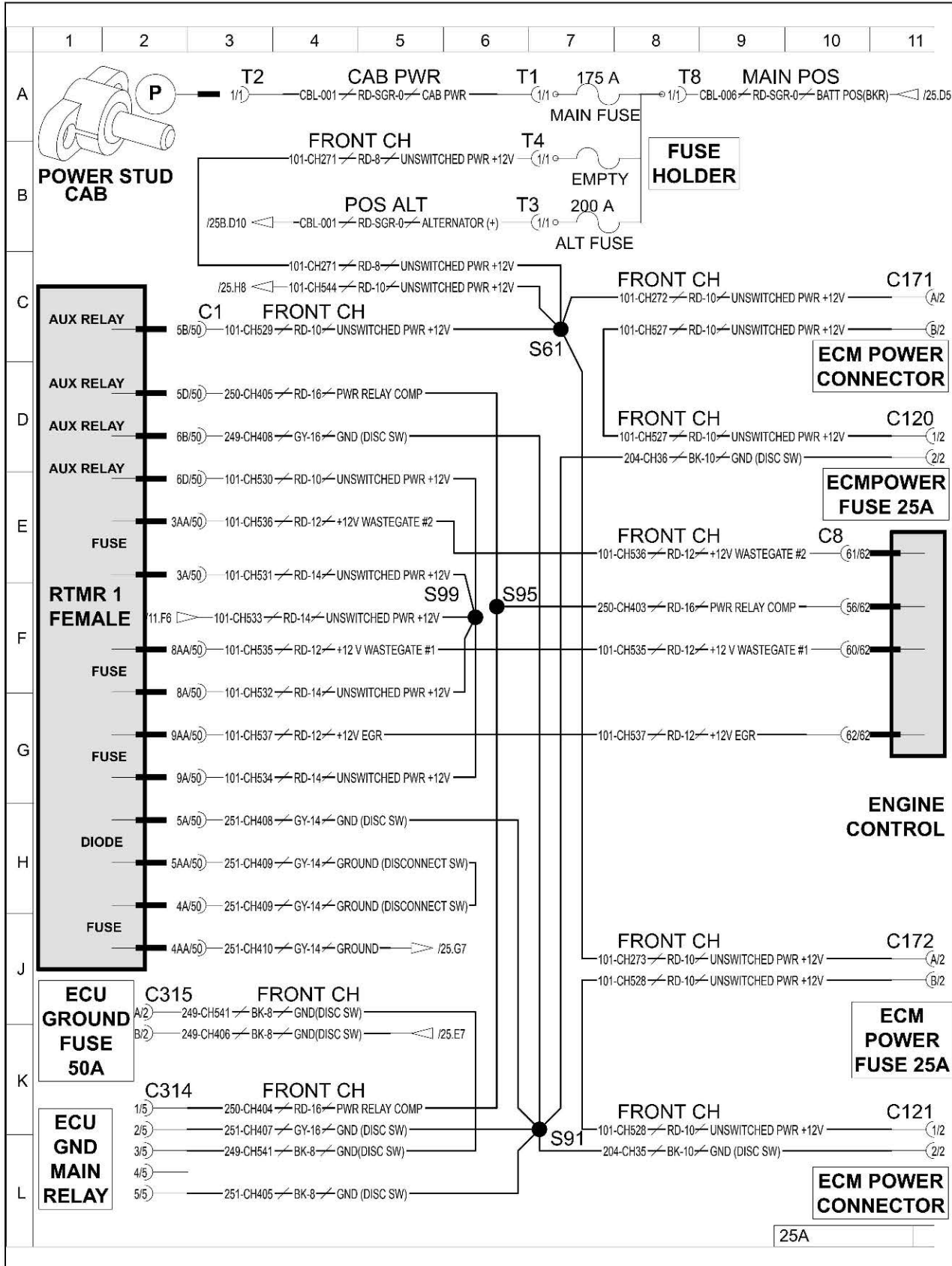

Fig. 54

18.2.51 Cab / Chassis pass through

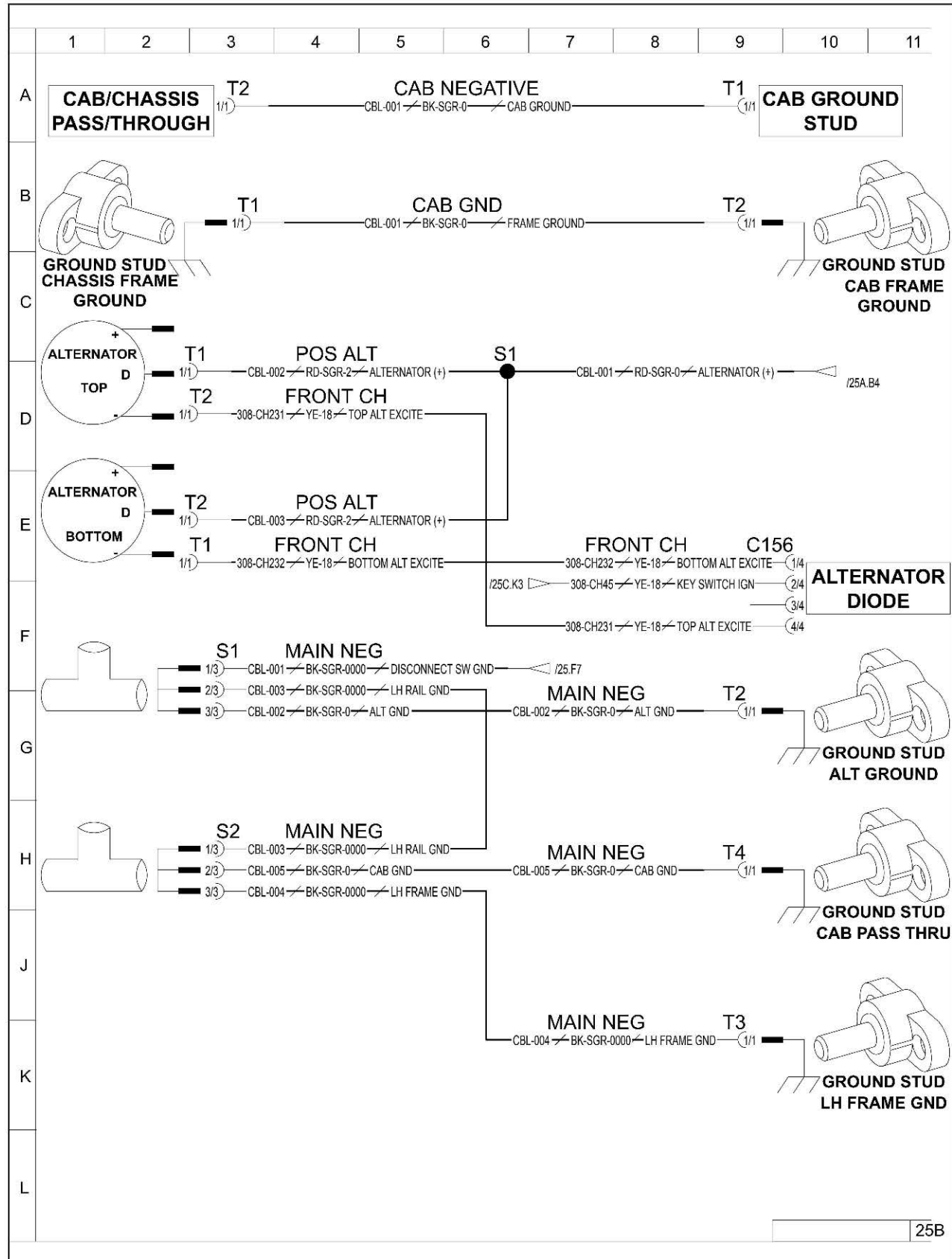

Fig. 55

18.2.52 Key start switch

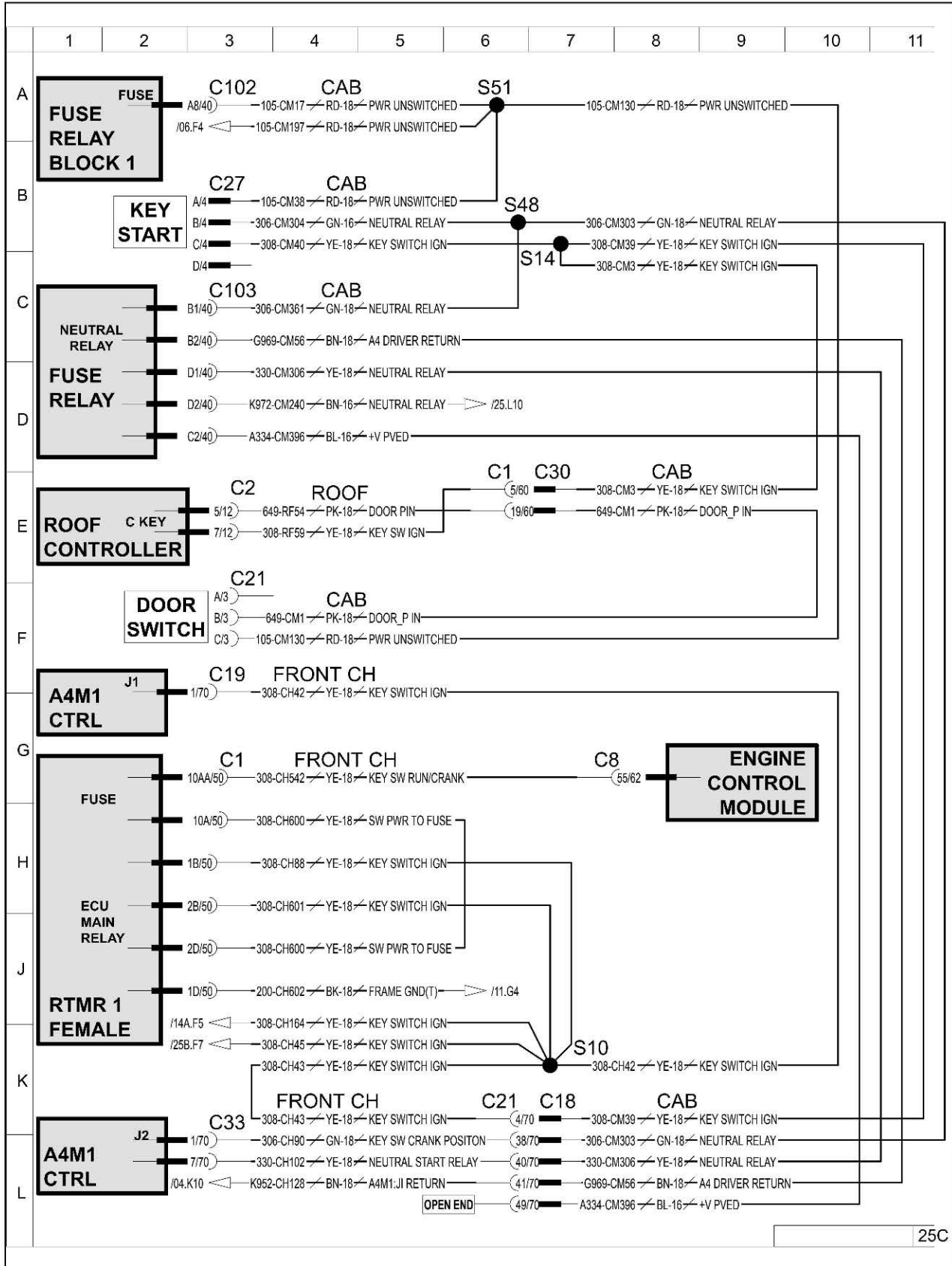

Fig. 56

18.2.53 Armrest 2

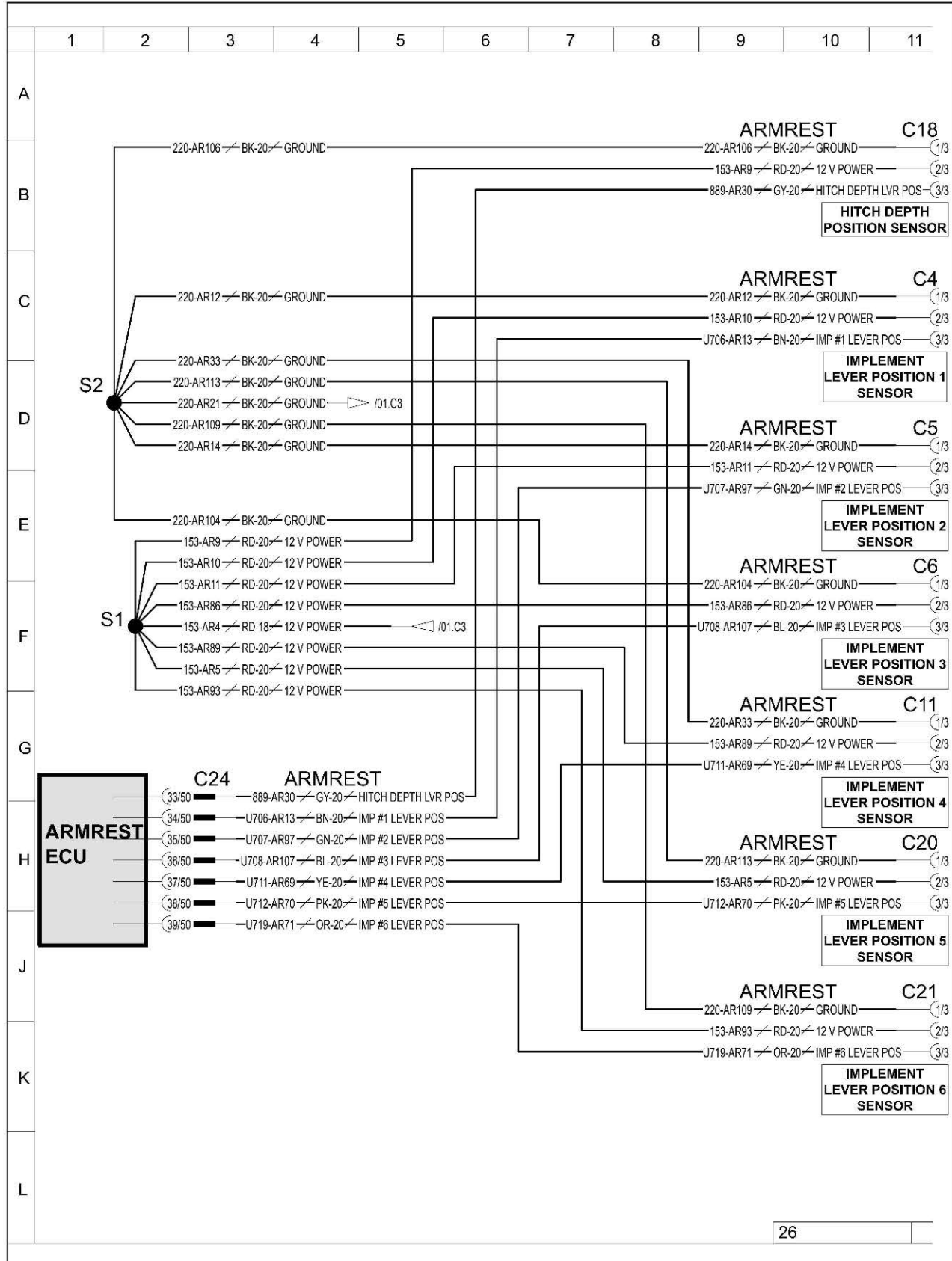

Fig. 57

18.2.54 Rear hitch

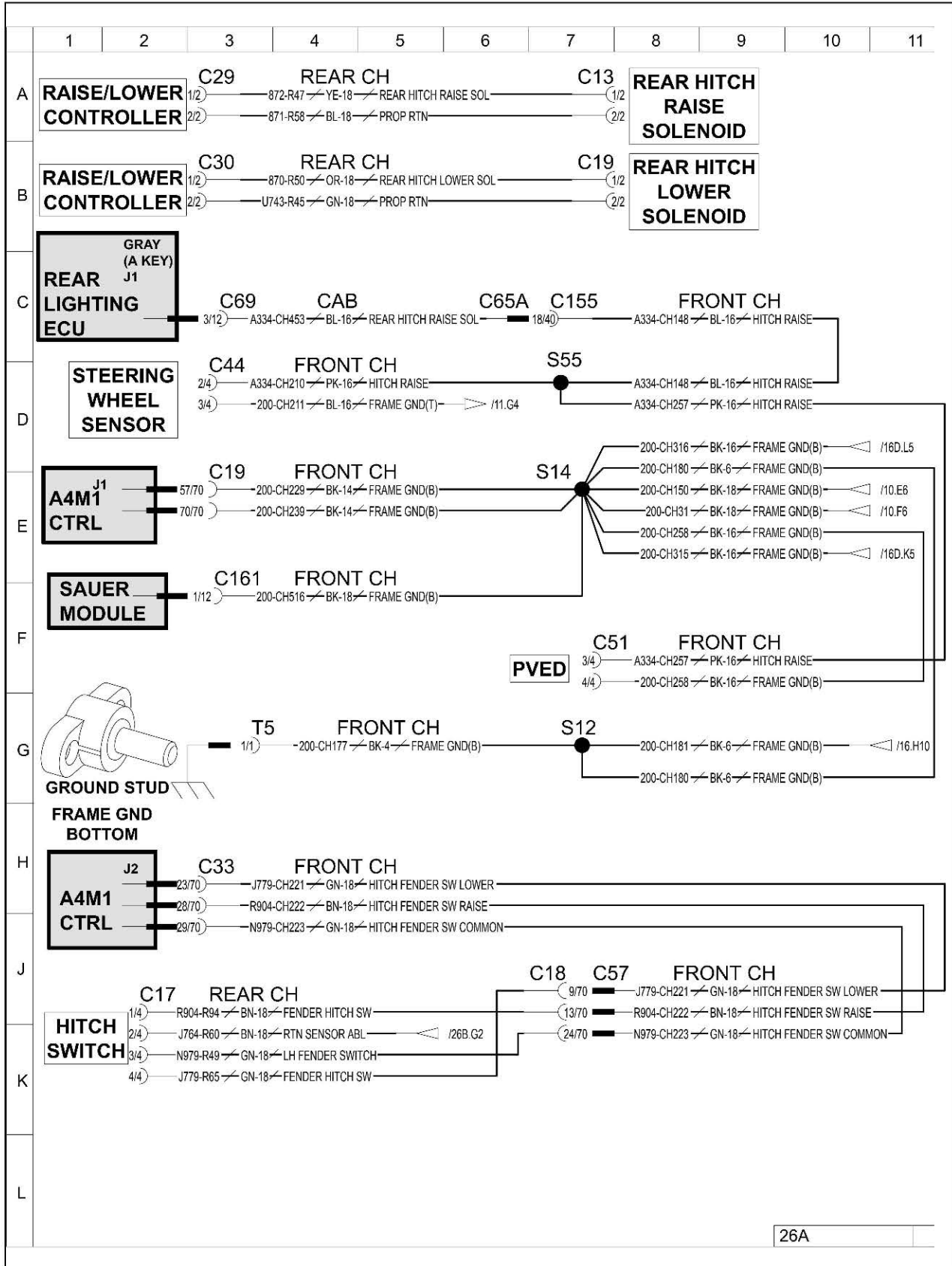

Fig. 58

18.2.56 Steering sensor box

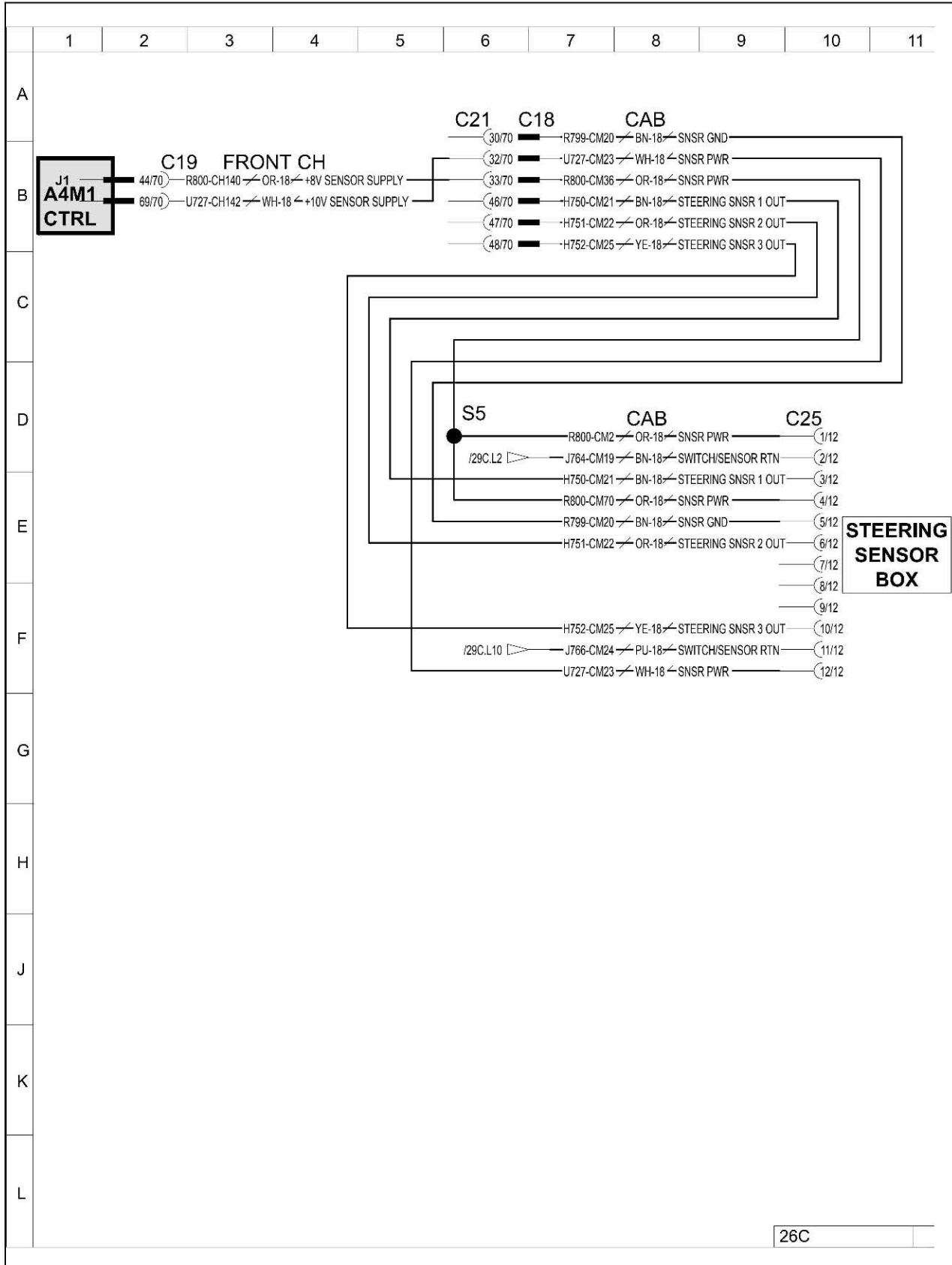

Fig. 60

18.2.57 Rear lighting

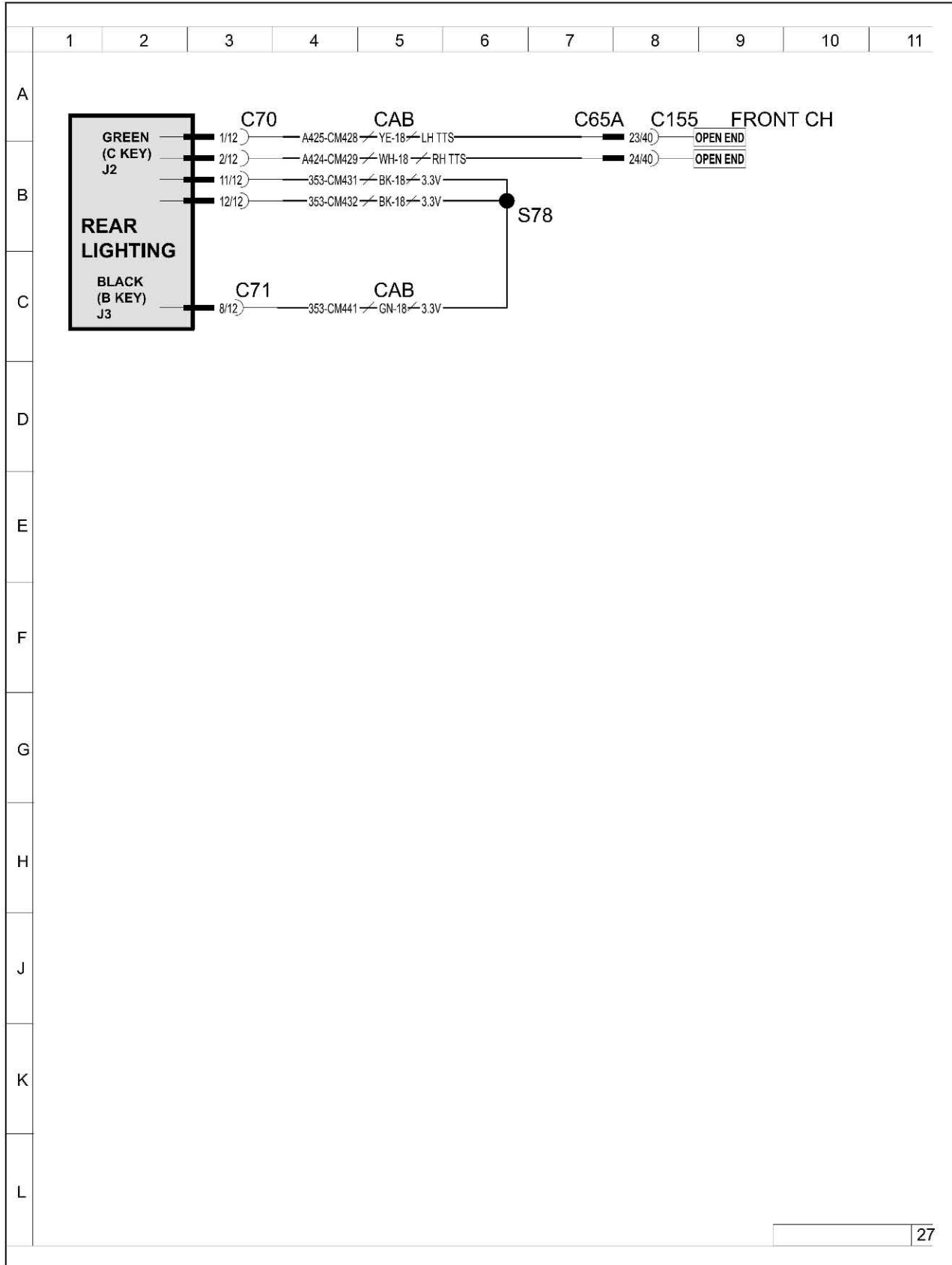

Fig. 61

18.2.58 Trailer lights

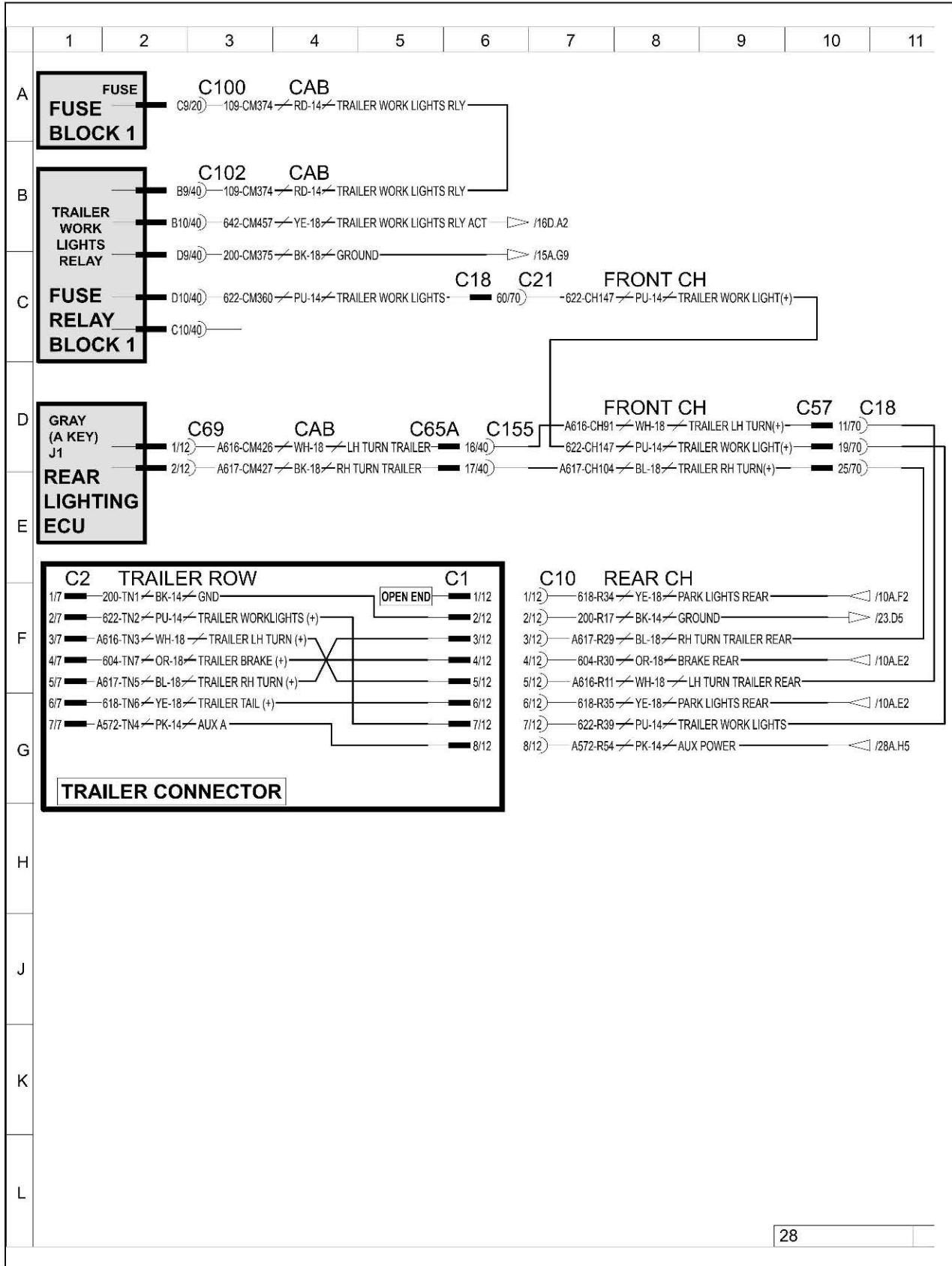

Fig. 62

18.2.59 Trailer auxiliary A switch

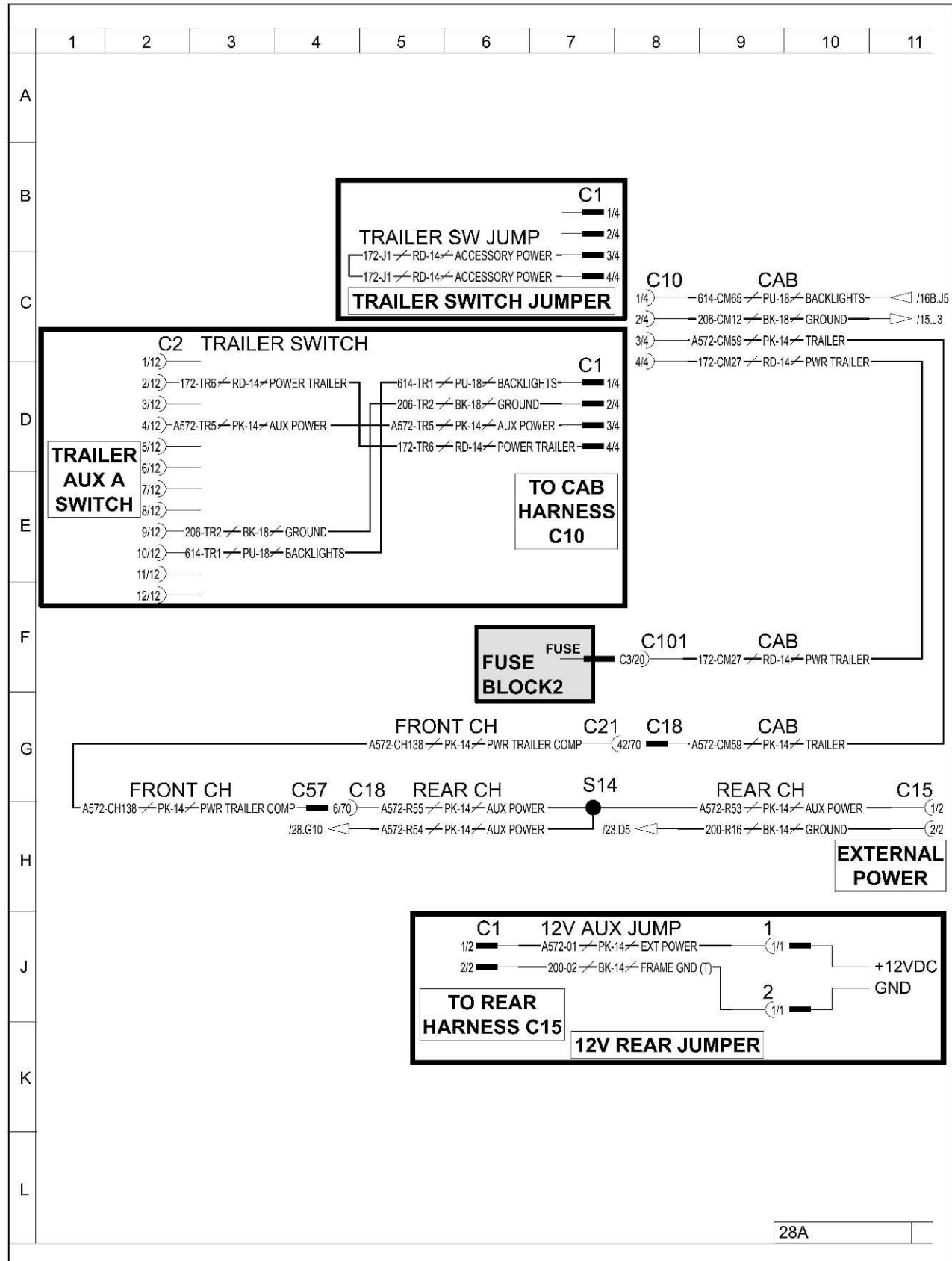

Fig. 63

18.2.60 Trans solenoids

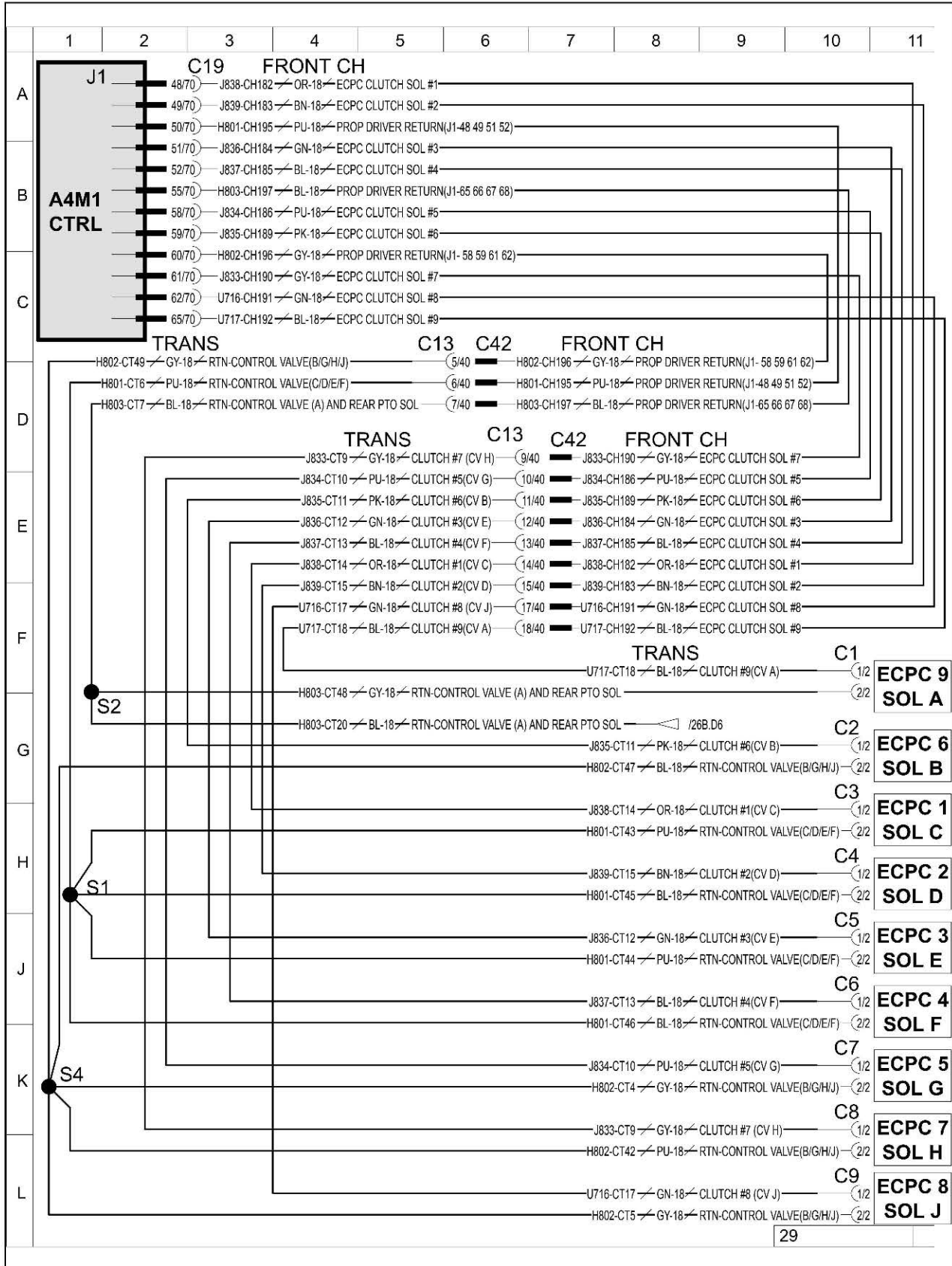

Fig. 64

18.2.61 Transmission sensors

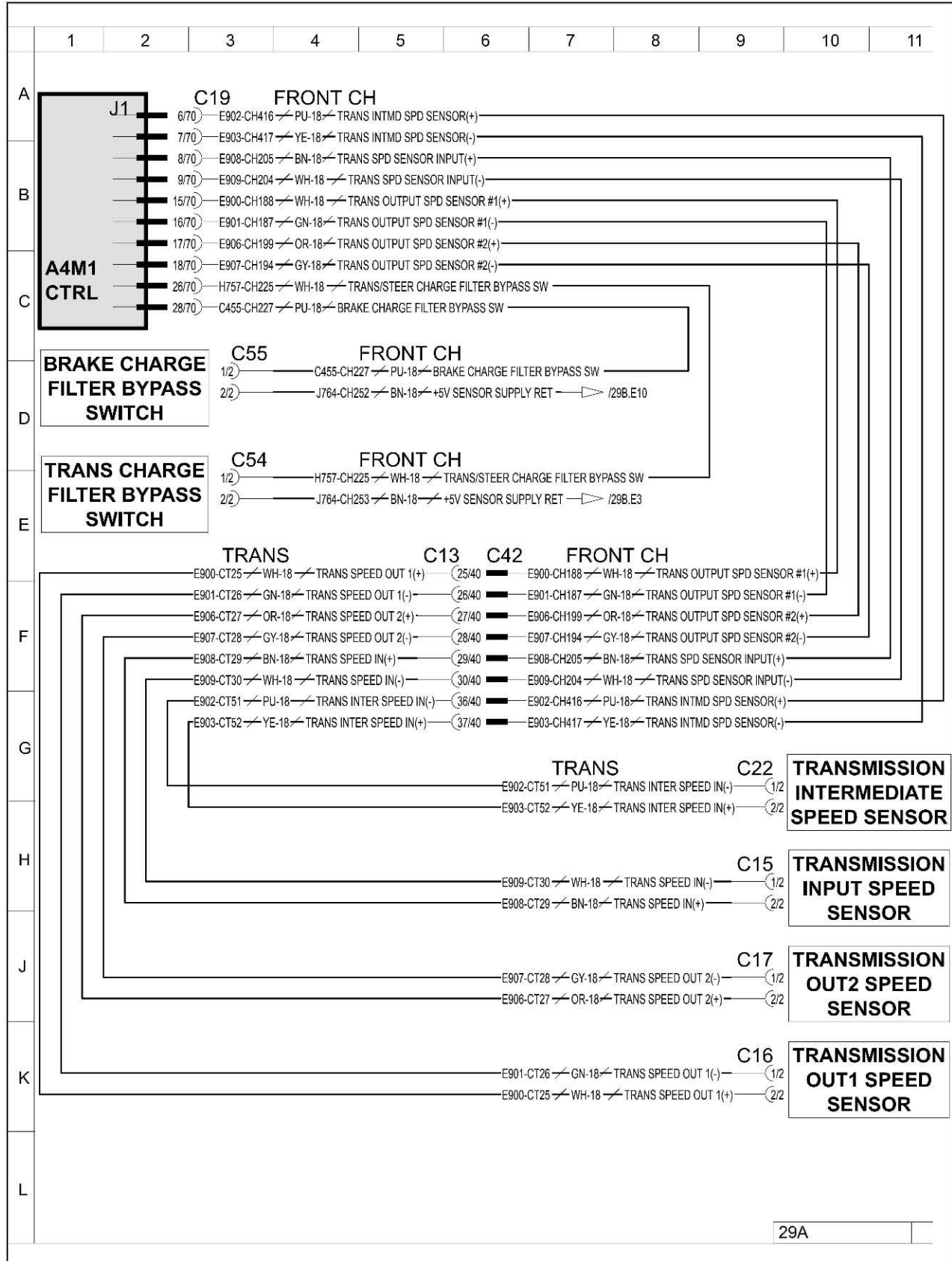

Fig. 65

18.2.62 Hydraulic oil switch

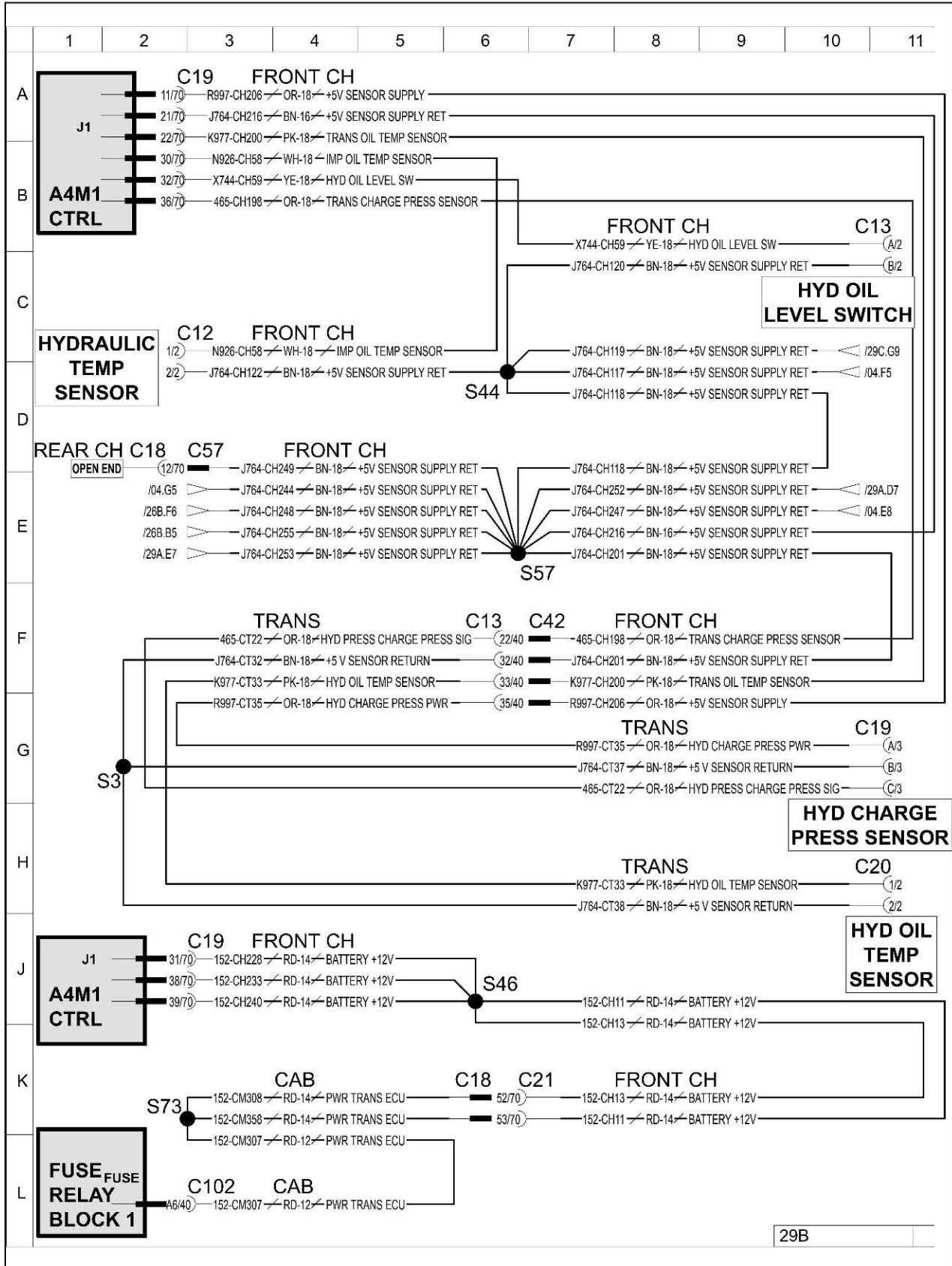

Fig. 66

18.2.63 Decel pedal sensor

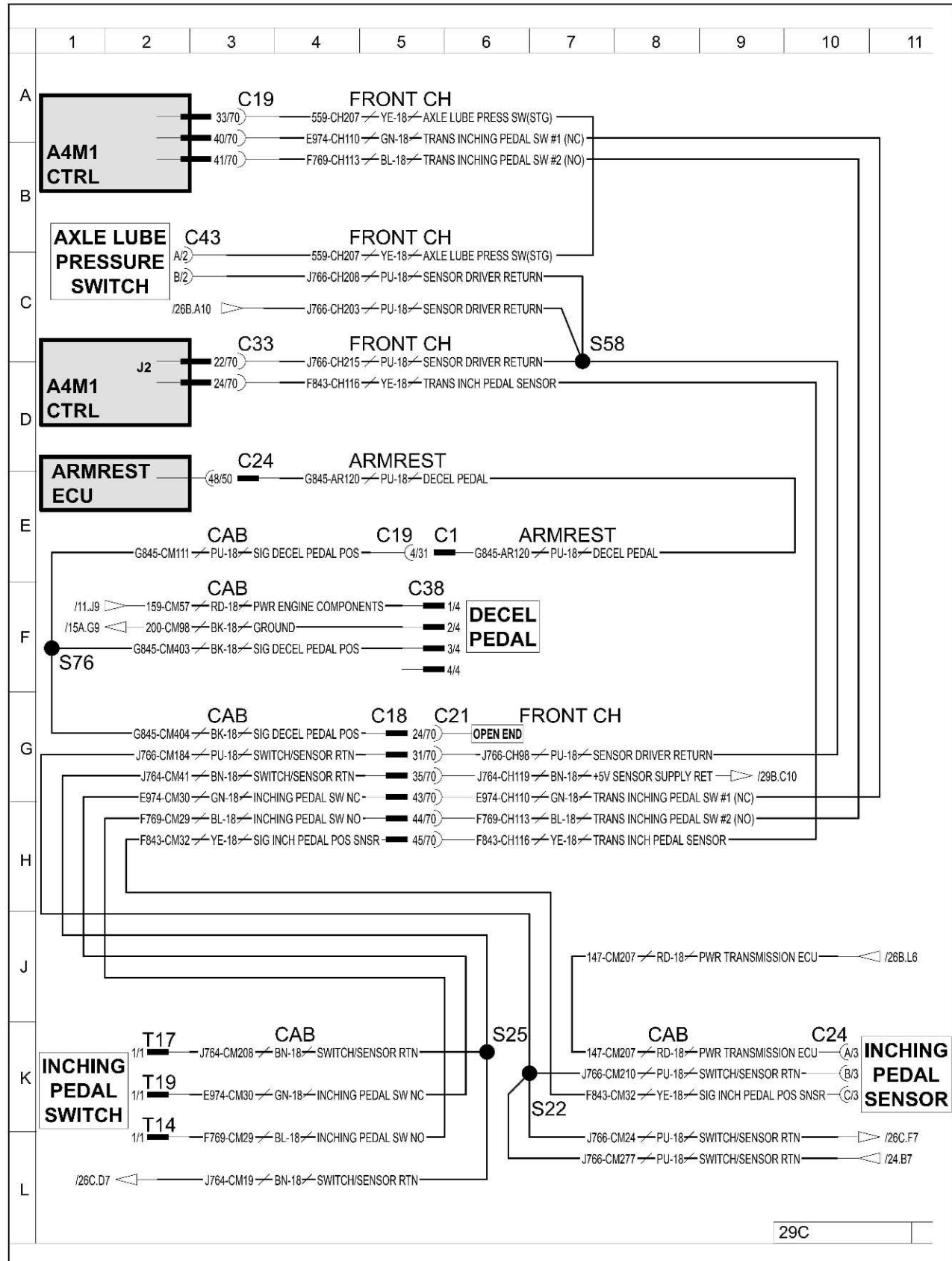

Fig. 67

18.2.64 Articulation sensor

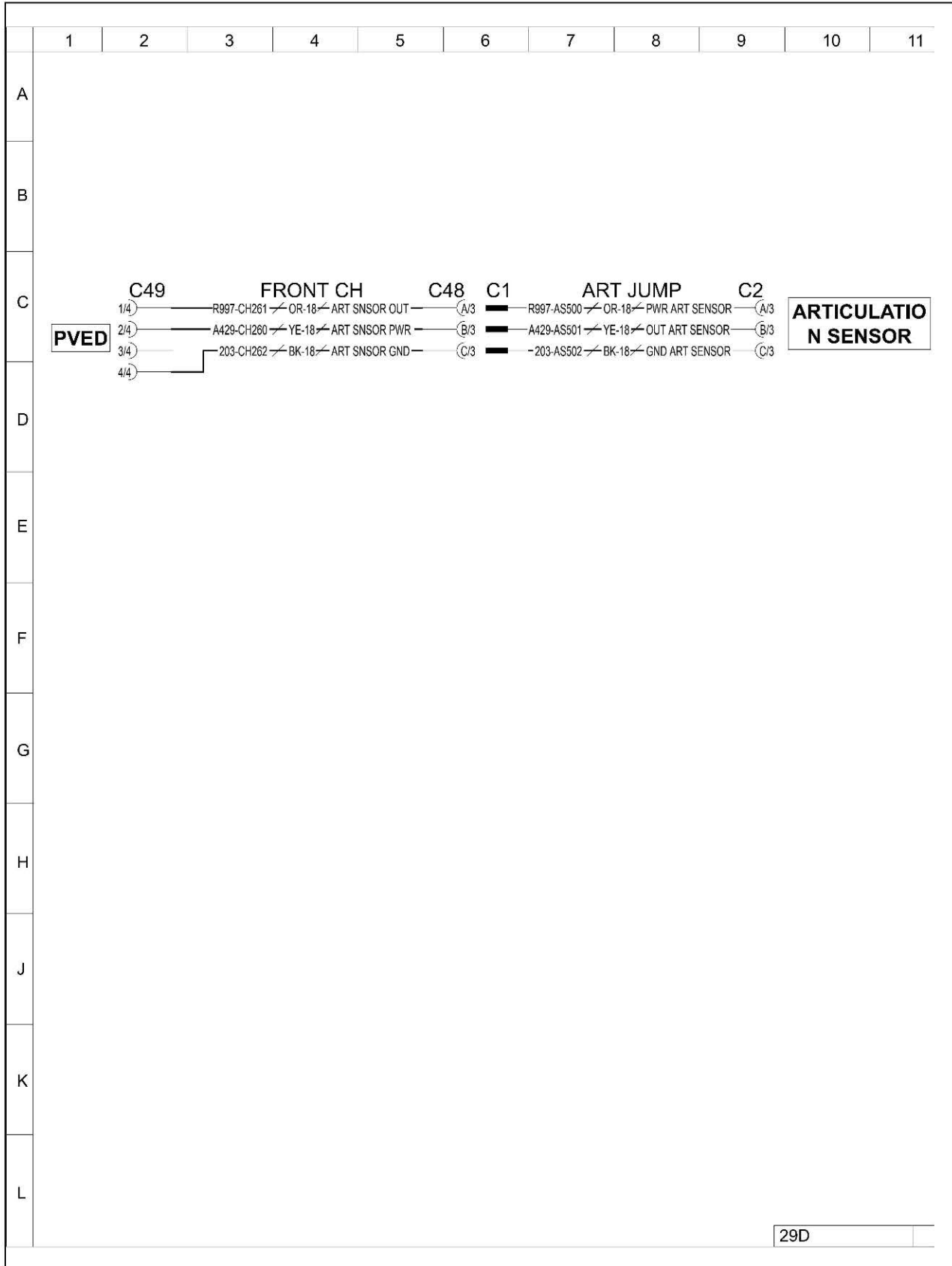

Fig. 68

18.2.65 Front and rear washer

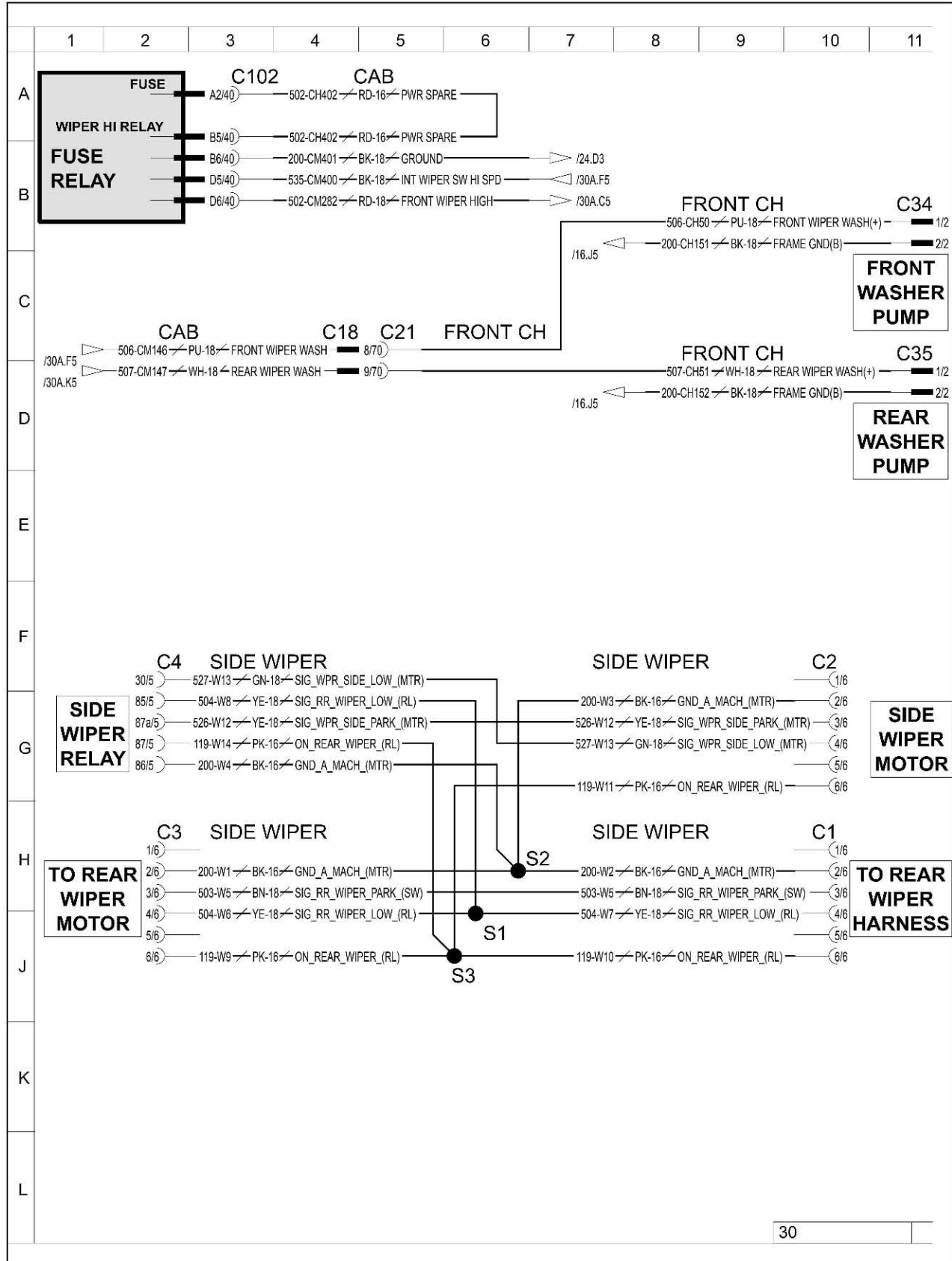

Fig. 69

18.2.66 Roof

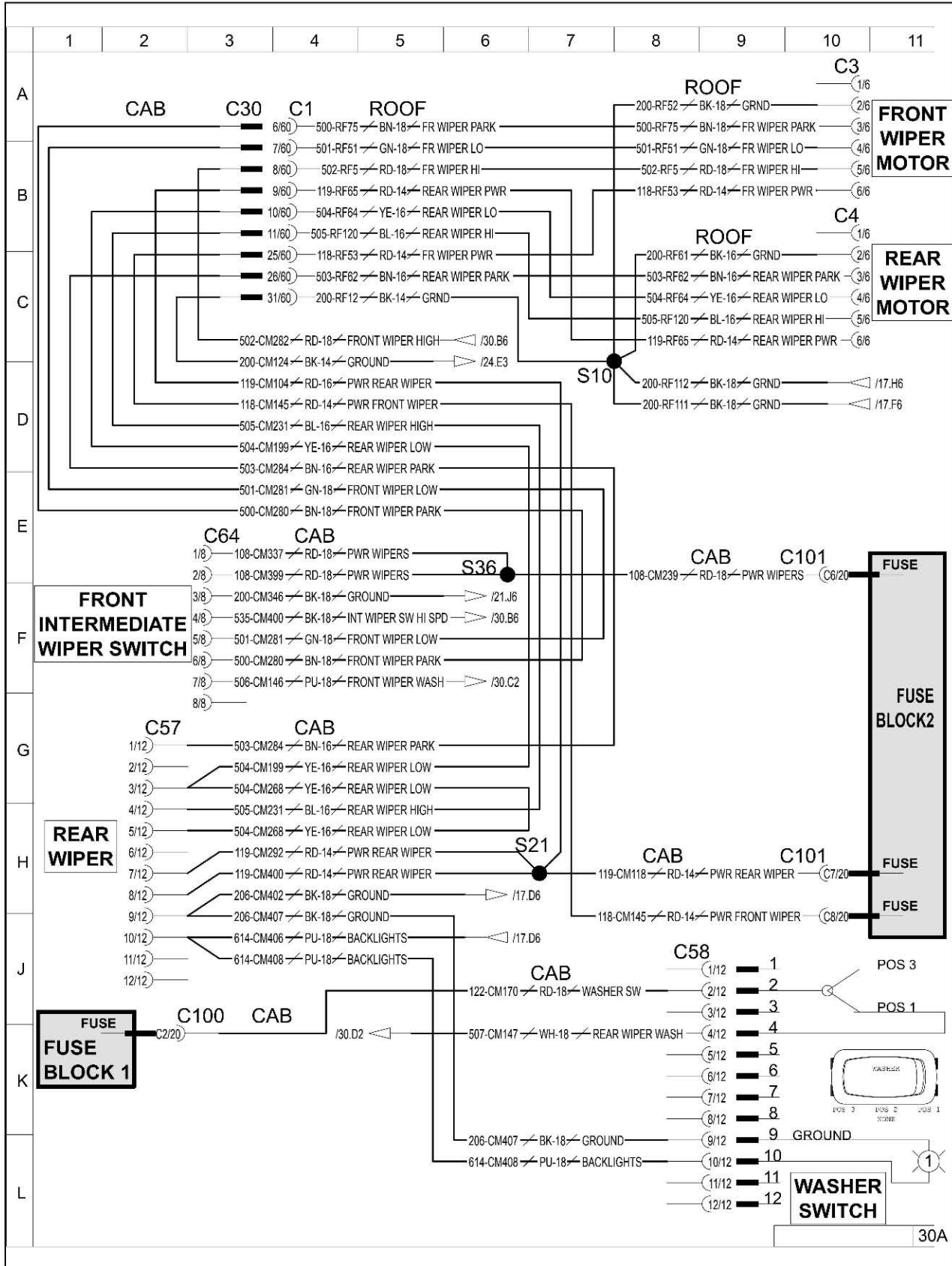

Fig. 70

18.3 Connector location diagrams

18.3.1 Battery group connector location diagram

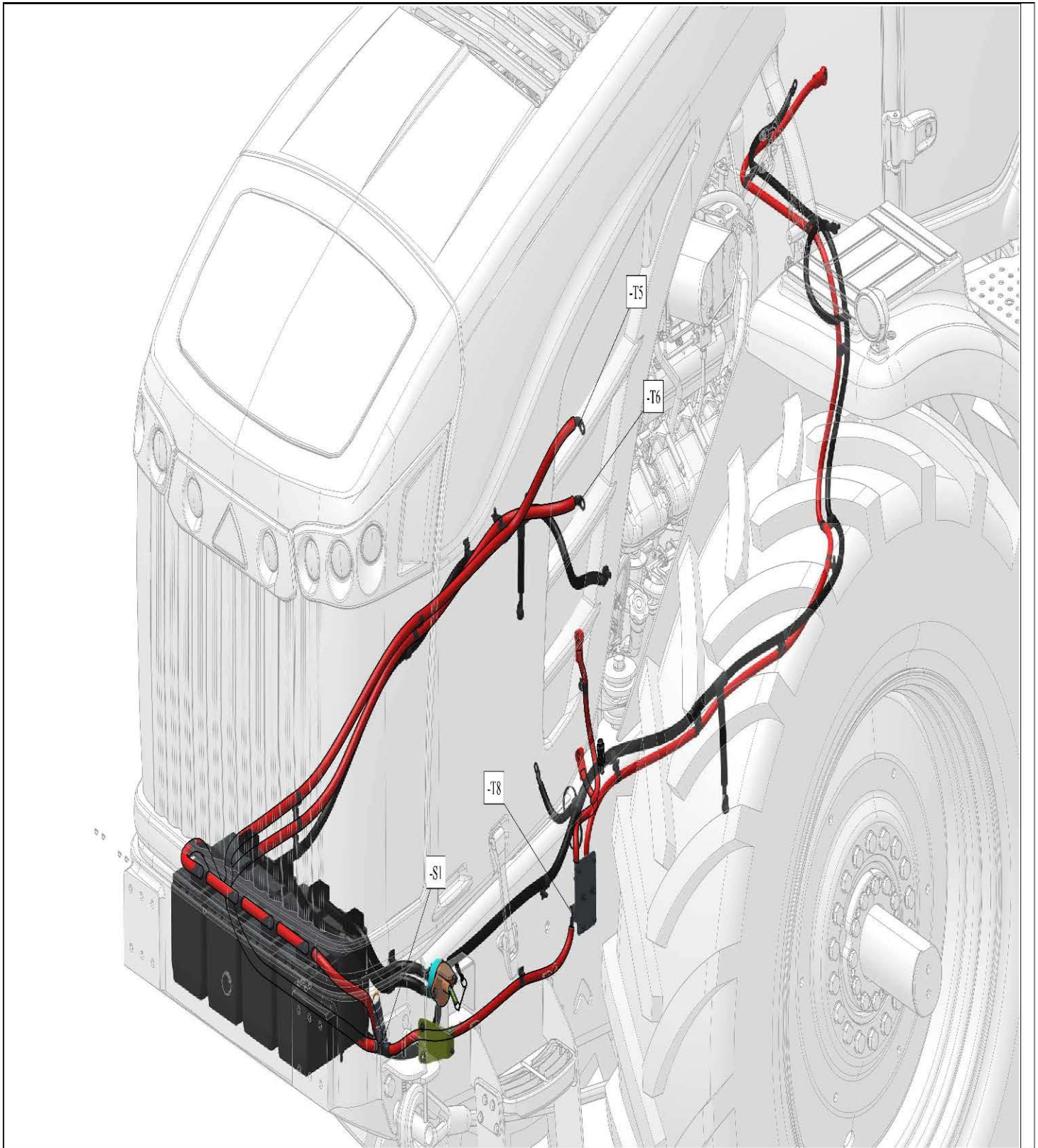

Fig. 71

18.3.3 Cab electrical top connector location diagram

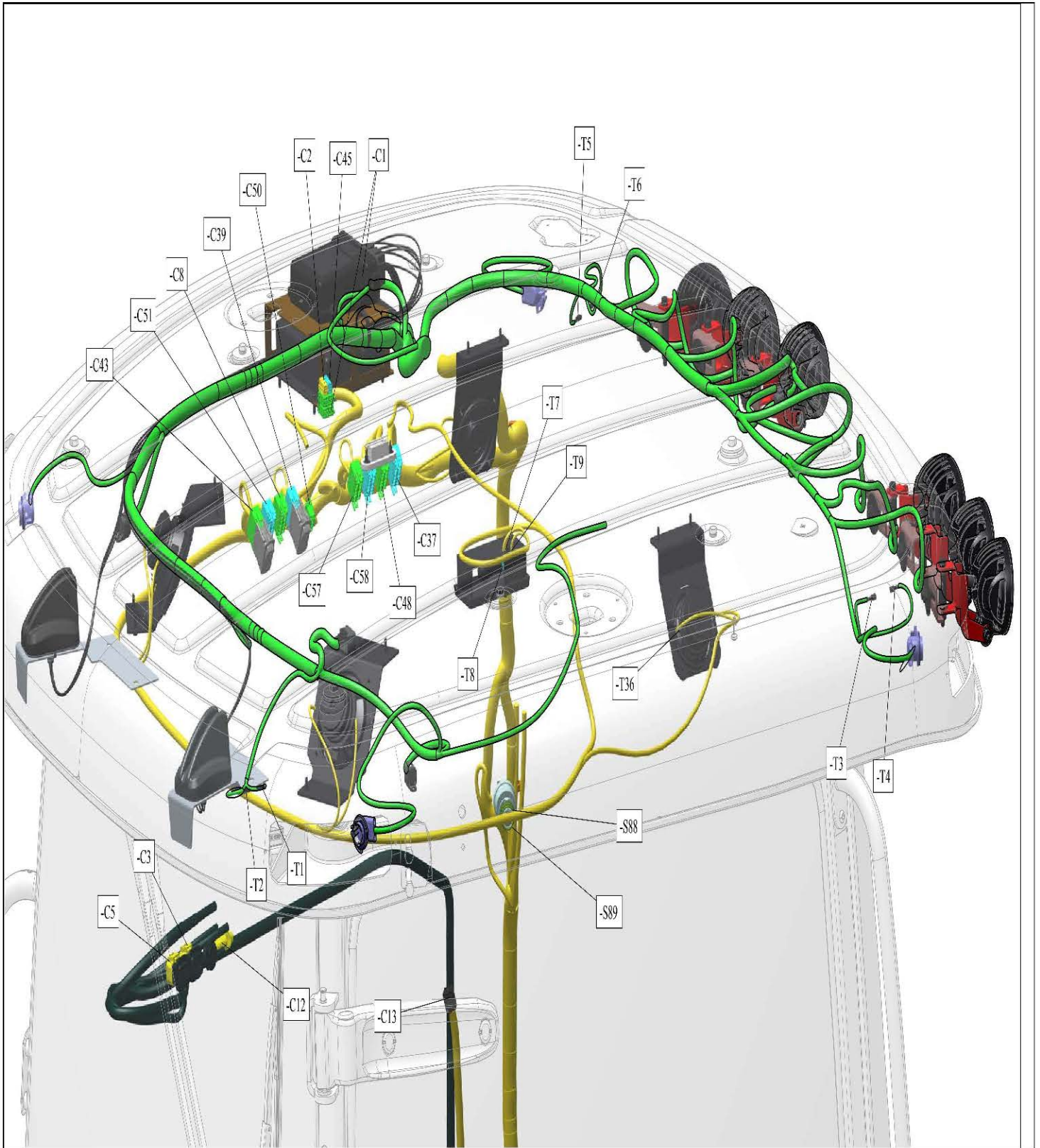

Fig. 73

18.3.5 Rear chassis electrical connector location diagram

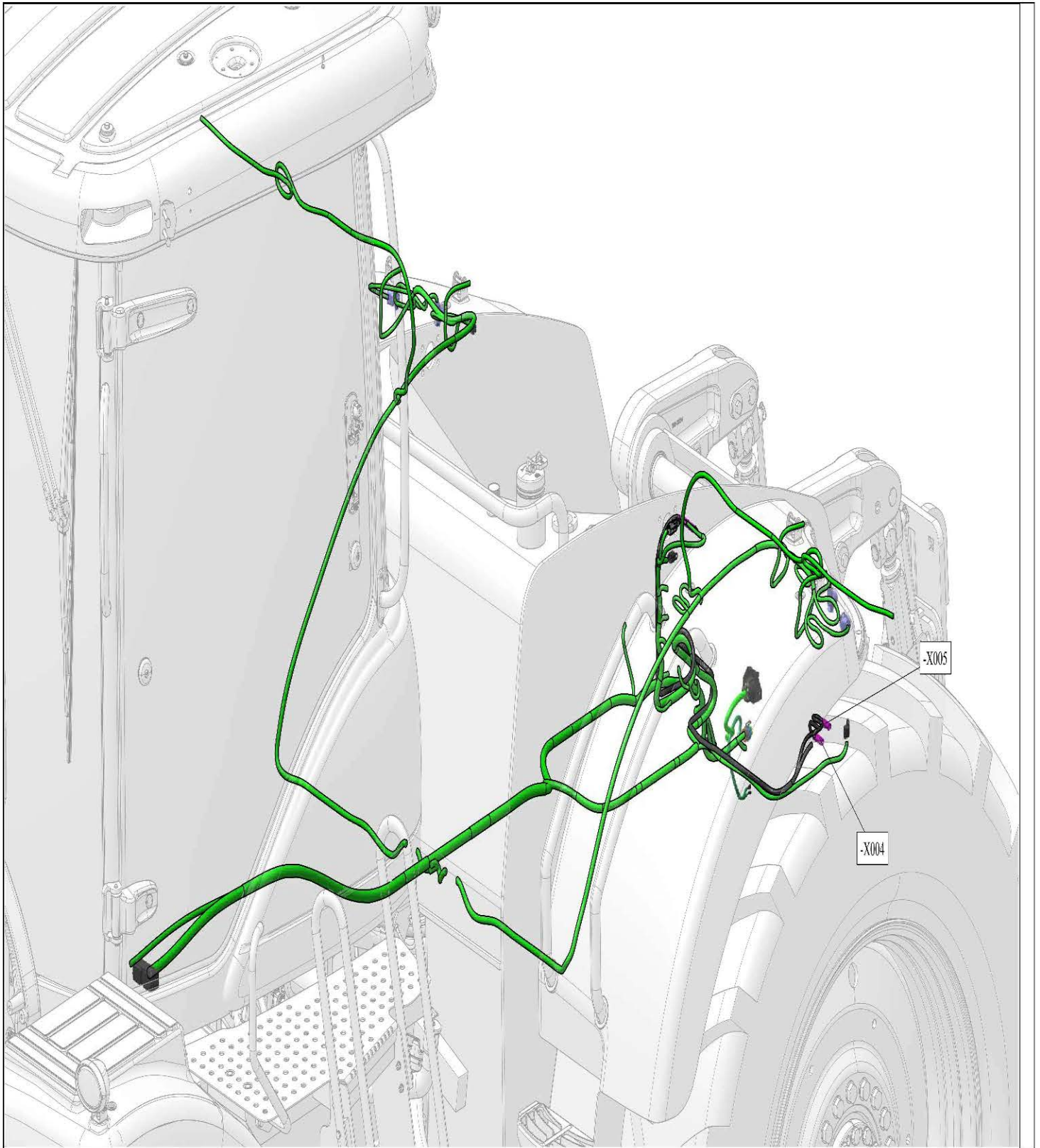

Fig. 75